

# LIST PRICE CATALOG



globally renowned



ZILMET is one of the oldest and largest expansion tank manufacturers in the world. Established in Italy in 1955, ZILMET is an international manufacturer of quality expansion vessels, pressure tanks and plate heat exchangers with several branches across the globe with worldwide distribution.

ZILMET is an ISO 9001 certified company that produces in excess of 7 million tanks and 1 million heat exchangers every year. We take great pride in our globally renowned quality and service and look forward to sharing our story and products with you and your customers.

With our North American Headquarters in North Kingstown, Rhode Island, ZILMET is proudly introducing new products for the hydronic, water system and solar industry into North America.

# Table Of Contents

|  |       |
|--|-------|
| ZILMET Hydro-Plus (ZHP) Well Tanks.....  | 2     |
| ZILMET Hydro-Plus (ZHPBC) Bottom Connection Well Tanks.....                        | 3     |
| ZILMET Easy Pro (ZEP) Thermal Expansion Tanks.....                                 | 4     |
| ZILMET Stainless Steel Expansion Tanks (ZS).....                                   | 5     |
| ZILMET ActivFlo.....   | 6-7   |
| ZILMET Maximizer.....  | 8     |
| ZILMET Cal Pro (ZHT)   |       |
| Hydronic Expansion Tanks.....  | 9     |
| Specialty Hydronic Tanks (ZFT & ZHT-R).....  | 10    |
| ZILMET Ultra Pro (ZUP) Potable Tanks with Replaceable Bladder.....                 | 11    |
| ZILMET Expansion Tank Accessories.....   | 12    |
| ZILMET Zil-Kit Boiler Trim Kit Package and Boiler Accessories.....                 | 13-15 |
| ZILMET IntaKlean2 Magnetic Filter.....   | 16    |
| ZILMET MAG PRO Magnetic Systems Hub.....   | 17    |
| ZILMET MAG PRO PLUS Magnetic Systems Hub.....                                      | 18    |
| ZILMET Heat Exchangers   |       |
| Plate and Frame.....   | 19-20 |
| Brazed Plate.....  | 21-22 |
| Commercial Products.....   | 23    |
| Commercial Accessories.....  | 24    |
| ZILMET Commercial Products   |       |
| ZILMET Hydronic Expansion Tank with Replaceable Bladder (ZELA).....                | 25    |
| ZILMET Hydronic Expansion Tank with Fixed Diaphragm (ZETA).....                    | 26    |
| ZILMET Thermal Expansion Tank with Replaceable Bladder (ZTXA).....                 | 27    |
| ZILMET Thermal Expansion Tank with Replaceable Bladder<br>Full Flow (ZTXA-FF)..... | 28    |
| ZILMET Thermal Expansion Tank with Fixed Diaphragm (ZTTA).....                     | 29    |
| ZILMET Hydro-Pneumatic Tank with Replaceable Bladder (ZHXA).....                   | 30-31 |
| ZILMET Hydro-Pneumatic Tank with Fixed Bladder (ZHXT).....                         | 32    |
| ZILMET Air and Dirt Separators (ZADS).....   | 33-34 |
| ZILMET Chilled Water Buffer Tanks (ZCBT) & Hot Water Buffer Tanks (ZHBT).....      | 35    |
| ZILMET Tangential Air Separators (ZPA).....  | 36    |
| ZILMET Hydraulic Separators (ZPSA & ZPSAV).....                                    | 37    |
| ZILMET Shock and Surge (ZSSA).....   | 38    |
| ZILMET Glycol Make Up (ZGMP).....  | 39    |
| ZILMET Warranty & Pallet Count List.....   | 40    |

# ZILMET Hydro-Plus (ZHP) Well Tanks



Certified to NSF/ANSI 61



Stainless steel side connection allows for quicker, less expensive installation →



## IN LINE MODELS

| Model Number | Volume (Gal) | Tank Weight (Lbs) | Connection Size (NPT) | Shipping Dimensions (LxWxH) | System Drawdown 30-50 (PSIG) | System Drawdown 40-60 (PSIG) | UPC Code (801985) | List Price (US \$) |
|--------------|--------------|-------------------|-----------------------|-----------------------------|------------------------------|------------------------------|-------------------|--------------------|
| ZEP5         | 2.1          | 6.0               | 3/4"                  | 9" x 9" x 13"               | 0.7                          | 0.6                          | 5041337           | \$ 302.40          |
| ZEP12        | 4.8          | 9.0               | 3/4"                  | 11" x 11" x 16"             | 1.6                          | 1.4                          | 5041344           | \$ 384.40          |
| ZEP18        | 6.3          | 12.0              | 3/4"                  | 12" x 12" x 18"             | 2.2                          | 1.9                          | 5041351           | \$ 564.48          |
| ZHP104IL     | 9.2          | 14.0              | 1"                    | 16" x 16" x 18"             | 3.1                          | 2.7                          | 5010241           | \$ 845.56          |
| ZHP200IL     | 13.2         | 20.0              | 1"                    | 16" x 16" x 23"             | 4.5                          | 3.9                          | 5010258           | \$ 1,091.84        |

## STAND MODELS

| Model Number | Volume (Gal) | Tank Weight (Lbs) | Connection Size (NPT) | Shipping Dimensions (LxWxH) | System Drawdown 30-50 (PSIG) | System Drawdown 40-60 (PSIG) | UPC Code (801985) | List Price (US \$) |
|--------------|--------------|-------------------|-----------------------|-----------------------------|------------------------------|------------------------------|-------------------|--------------------|
| ZHP200F      | 13.2         | 20.0              | 1"                    | 16" x 16" x 23"             | 4.5                          | 3.9                          | 5010562           | \$1,168.40         |
| ZHP202       | 21.1         | 31.0              | 1"                    | 18" x 18" x 26"             | 7.2                          | 6.2                          | 5010272           | \$1,417.28         |
| ZHP203       | 27.7         | 43.0              | 1 1/4"                | 20" x 20" x 28"             | 9.5                          | 8.2                          | 5010289           | \$1,935.20         |
| ZHP204       | 39.6         | 54.0              | 1 1/4"                | 20" x 20" x 37"             | 13.5                         | 11.7                         | 5010296           | \$2,718.24         |
| ZHP250       | 52.8         | 73.0              | 1 1/4"                | 24" x 24" x 34"             | 18.0                         | 15.6                         | 5010838           | \$3,280.96         |
| ZHP251       | 66.0         | 98.0              | 1 1/4"                | 25" x 25" x 40"             | 22.5                         | 19.5                         | 5010302           | \$3,552.32         |
| ZHP302       | 79.3         | 106.0             | 1 1/4"                | 25" x 25" x 47"             | 27.0                         | 23.4                         | 5010845           | \$4,460.80         |
| ZHP350       | 105.7        | 128.0             | 1 1/4"                | 25" x 25" x 61"             | 36.0                         | 31.2                         | 5010319           | \$6,020.00         |
| ZHP351       | 119.0        | 125.0             | 1 1/4"                | 30" x 30" x 46"             | 40.6                         | 35.1                         | 5046998           | \$7,425.80         |
| ZHP400       | 132.1        | 166.0             | 1 1/4"                | 30" x 30" x 55"             | 45.0                         | 39.0                         | 5010852           | \$8,647.20         |
| ZHP451       | 158.5        | 182.0             | 1 1/4"                | 30" x 30" x 64"             | 54.0                         | 46.8                         | 5010326           | \$10,400.00        |

## SPECIALTY TANKS

| Model Number | Volume (Gal) | Tank Weight (Lbs) | Connection Size (NPT) | Shipping Dimensions (LxWxH) | System Drawdown 30-50 (PSIG) | System Drawdown 40-60 (PSIG) | UPC Code (801985) | List Price (US \$) |
|--------------|--------------|-------------------|-----------------------|-----------------------------|------------------------------|------------------------------|-------------------|--------------------|
| ZHP24H**     | 6.3          | 13.0              | 1"                    | 19" X 13" X 15"             | 2.2                          | 1.9                          | 5043751           | \$655.00           |
| ZHP200BH**   | 13.0         | 20.0              | 1"                    | 22" X 15" X 18"             | 4.5                          | 3.9                          | 5010265           | \$1,270.92         |
| ZHP202BV*    | 21.1         | 31.0              | 1"                    | 18" X 18" X 26"             | 7.2                          | 6.2                          | 5010555           | \$1,522.92         |
| ZHP202BH**   | 21.1         | 31.0              | 1"                    | 18" X 18" X 26"             | 7.2                          | 6.2                          | 5010814           | \$1,523.08         |
| ZHP202SM**   | 21.1         | 30.0              | 1"                    | 18" X 18" X 26"             | 7.2                          | 6.2                          | 5010821           | \$1,523.08         |

\* Vertical tank with welded pump mounting bracket \*\* Horizontal tank with welded pump mounting bracket \*\*\* Horizontal tank with no pump bracket

| Description | Material        | Operating Conditions    |          |
|-------------|-----------------|-------------------------|----------|
| shell       | carbon steel    | max. operating pressure | 150 PSIG |
| connection  | stainless steel | operating temperature   | 210° F   |
| diaphragm   | butyl           | factory precharge       | 38 PSIG  |
| color       | almond          | warranty                | 5 years  |

### TANK WITH UNION



**ZTT-1**  
1" connection  
List Price: \$98.00



**ZTT-2**  
1 1/4" connection  
List Price: \$137.20

-Please see page 12 for tank accessories

SEE OUR WEBSITE FOR TANK SIZING CALCULATOR

# ZILMET Hydro-Plus (ZHPBC) Bottom Connection Well Tanks



## TECHNICAL FEATURES

- 150 PSIG Rated
- All weather epoxy powder coated paint
- Stainless steel elbow
- Polypropylene base for all weather applications
- 5 year manufacturer's warranty

| Model Number | Volume (Gal) | Tank Weight (Lbs) | Connection Size (NPT) | Shipping Dimensions (LxWxH) | System Drawdown 30-50 (PSIG) | System Drawdown 40-60 (PSIG) | UPC Code (801985) | List Price (US \$) |
|--------------|--------------|-------------------|-----------------------|-----------------------------|------------------------------|------------------------------|-------------------|--------------------|
| ZHP202BC     | 21.1         | 32.0              | 1"                    | 18" x 18" x 28"             | 7.2                          | 6.2                          | 5052586           | \$1,702.40         |
| ZHP202BV-BC  | 21.1         | 27.0              | 1"                    | 18" x 18" x 28"             | 7.2                          | 6.2                          | 5054894           | \$1,808.20         |
| ZHP203BC     | 27.7         | 44.0              | 1 1/4"                | 18" x 18" x 30"             | 9.4                          | 8.2                          | 5054900           | \$2,220.32         |
| ZHP34BC      | 34.1         | 43.8              | 1 1/4"                | 20" x 20" x 35"             | 11.6                         | 10.0                         | 5055785           | \$3,136.72         |
| ZHP204BC     | 39.6         | 56.0              | 1 1/4"                | 20" x 20" x 40"             | 13.5                         | 11.7                         | 5052593           | \$3,313.60         |
| ZHP250BC     | 54.7         | 71.0              | 1 1/4"                | 20" x 20" x 51"             | 18.7                         | 16.1                         | 5055594           | \$4,403.24         |
| ZHP302BC     | 79.3         | 117.4             | 1 1/4"                | 26" x 26" x 48"             | 27.0                         | 23.4                         | 5055952           | \$5,161.76         |
| ZHP351BC     | 119.0        | 180.0             | 1 1/4"                | 26" x 26" x 67"             | 40.6                         | 35.1                         | 5055969           | \$8,018.24         |

## DIMENSIONAL DATA

| Model Number | Diameter | Height | Base Diameter | Connection Height | Connection Size |
|--------------|----------|--------|---------------|-------------------|-----------------|
| ZHP202BC     | 17.7"    | 26.9"  | 16.8"         | 1.6"              | 1"              |
| ZHP202BV-BC  | 17.7"    | 27.9"  | 16.8"         | 1.6"              | 1"              |
| ZHP203BC     | 19.7"    | 29.2"  | 16.8"         | 1.6"              | 1 1/4"          |
| ZHP34BC      | 19.7"    | 33.9"  | 16.8"         | 1.6"              | 1 1/4"          |
| ZHP204BC     | 19.7"    | 38.3"  | 16.8"         | 1.6"              | 1 1/4"          |
| ZHP250BC     | 19.7"    | 49.7"  | 16.8"         | 1.6"              | 1 1/4"          |
| ZHP302BC     | 24.8"    | 46.9"  | 21.6"         | 2.1"              | 1 1/4"          |
| ZHP351BC     | 24.8"    | 65.9"  | 21.6"         | 2.1"              | 1 1/4"          |

| Description      | Material        |
|------------------|-----------------|
| shell            | carbon steel    |
| connection       | stainless steel |
| fixed membrane   | butyl           |
| material of base | polypropylene   |
| tank color       | blue            |
| base color       | grey            |

| Operating Conditions    |          |
|-------------------------|----------|
| max. operating pressure | 150 PSIG |
| operating temperature   | 210° F   |
| factory precharge       | 38 PSIG  |
| warranty                | 5 years  |

- Please see page 12 for tank accessories

[SEE OUR WEBSITE FOR TANK SIZING CALCULATOR](#)

# ZILMET Easy Pro (ZEP) Thermal Expansion Tanks



## ZEP1

Stainless steel thermal expansion tanks for on demand and POU water heaters with up to 2 gallon of total water volume.

### SPECIALTY TANKS: ZEP1 IS UPC CERTIFIED

| Model Number | Tank Weight (Lbs) | Connection Size (NPT) | Shipping Dimensions (LxWxH) | Sized for up to (Gal) | UPC Code (801985) | List Price (US \$) |
|--------------|-------------------|-----------------------|-----------------------------|-----------------------|-------------------|--------------------|
| ZEP1         | 0.5               | 1/2"                  | 3" x 3" x 3"                | 2                     | 5054139           | \$256.00           |

### IN LINE MODELS: ALL IN LINE TANKS ARE UPC CERTIFIED

| Model Number | Volume (Gal) | Tank Weight (lbs) | Connection Size (NPT) | Shipping Dimensions (LxWxH) | Acceptance Volume (Gal) | UPC Code (801985) | List Price (US \$) |
|--------------|--------------|-------------------|-----------------------|-----------------------------|-------------------------|-------------------|--------------------|
| ZEP5         | 2.1          | 5.0               | 3/4"                  | 9" x 9" x 13"               | 1.4                     | 5041337           | \$302.40           |
| ZEP12        | 4.8          | 9.0               | 3/4"                  | 11" x 11" x 16"             | 3.3                     | 5041344           | \$384.40           |
| ZEP18        | 6.3          | 11.0              | 3/4"                  | 12" x 12" x 18"             | 4.3                     | 5041351           | \$564.48           |
| ZHP104IL     | 9.2          | 20.0              | 1"                    | 16" x 16" x 18"             | 6.3                     | 5010241           | \$845.56           |
| ZHP200IL     | 13.2         | 20.0              | 1"                    | 16" x 16" x 23"             | 9.0                     | 5010258           | \$545.92           |

### STAND MODELS

| Model Number | Volume (Gal) | Tank Weight (Lbs) | Connection Size (NPT) | Shipping Dimensions (LxWxH) | Acceptance Volume (Gal) | UPC Code (801985) | List Price (US \$) |
|--------------|--------------|-------------------|-----------------------|-----------------------------|-------------------------|-------------------|--------------------|
| ZHP200F      | 13.2         | 20.0              | 1"                    | 16" x 16" x 23"             | 9.0                     | 5010562           | \$1,091.84         |
| ZHP200BH*    | 13.2         | 20.0              | 1"                    | 25" x 15.5" x 18"           | 9.0                     | 5010265           | \$1,523.08         |
| ZHP202       | 21.1         | 31.0              | 1"                    | 18" x 18" x 26"             | 14.4                    | 5100272           | \$1,417.28         |
| ZHP202BH*    | 21.1         | 31.0              | 1"                    | 28" x 19" x 19"             | 14.4                    | 5010814           | \$2,718.24         |
| ZHP203       | 27.7         | 40.0              | 1 1/4"                | 20" x 20" x 28"             | 18.9                    | 5010289           | \$1,935.20         |
| ZHP204       | 39.6         | 54.0              | 1 1/4"                | 20" x 20" x 37"             | 27.0                    | 5010296           | \$2,718.24         |
| ZHP250       | 52.8         | 73.0              | 1 1/4"                | 24" x 24" x 34"             | 36.0                    | 5010838           | \$3,280.96         |
| ZHP251       | 66.0         | 98.0              | 1 1/4"                | 25" x 25" x 40"             | 44.9                    | 5010302           | \$3,552.32         |
| ZHP302       | 79.3         | 106.0             | 1 1/4"                | 25" x 25" x 47"             | 54.0                    | 5010845           | \$4,460.80         |

\*Horizontal model with pump

| Description | Material        |
|-------------|-----------------|
| shell       | carbon steel    |
| connection  | stainless steel |
| diaphragm   | butyl           |
| color       | almond          |

| Operating Conditions    |          |
|-------------------------|----------|
| max. operating pressure | 150 PSIG |
| operating temperature   | 210° F   |
| factory precharge       | 40 PSIG  |
| warranty                | 5 years  |

| ZEP1                  | Material & Conditions |
|-----------------------|-----------------------|
| shell                 | stainless steel       |
| connection            | stainless steel       |
| max. pressure         | 150 PSIG              |
| operating temperature | 210° F                |
| factory precharge     | 50 PSIG               |
| warranty              | 5 years               |

- Please see page 12 for tank accessories

**SEE OUR WEBSITE FOR TANK SIZING CALCULATOR**

# ZILMET Inox Pro & Ultra Inox Pro (ZS) Stainless Steel Expansion Tanks



**SEE PAGE 23 FOR  
STAINLESS STEEL  
ASME RATED TANKS**



**ZILMET INOX PRO  
& ULTRA INOX PRO (ZS)**  
All tanks manufactured  
with 304 Stainless Steel

Models ZS8, ZS12 and  
ZS18 are NSF61 Certified

## IN LINE MODELS

## INOX PRO – FIXED DIAPHRAGM MODELS

| Model Number | Volume (Gal) | Tank Weight (Lbs) | Connection Size (NPT) | Shipping Dimensions (LxWxH) | Acceptance Volume (Gal) | UPC Code (801985) | List Price (US \$) |
|--------------|--------------|-------------------|-----------------------|-----------------------------|-------------------------|-------------------|--------------------|
| ZS160        | 0.04         | 0.5               | 1/4"                  | 4" x 4" x 3"                | N/A                     | N/A               | \$182.76           |
| ZS05         | 0.13         | 0.9               | 1/2"                  | 4" x 4" x 5"                | 0.1                     | 5043355           | \$229.30           |
| ZS1          | 0.26         | 1.2               | 1/2"                  | 5" x 5" x 7"                | 0.2                     | 5043362           | \$294.80           |
| ZS2          | 0.53         | 2.0               | 1/2"                  | 6" x 6" x 8"                | 0.3                     | 5039945           | \$327.50           |

## IN LINE MODELS

| Model Number | Volume (Gal) | Tank Weight (Lbs) | Connection Size (NPT) | Shipping Dimensions (LxWxH) | Acceptance Volume (Gal) | UPC Code (801985) | List Price (US \$) |
|--------------|--------------|-------------------|-----------------------|-----------------------------|-------------------------|-------------------|--------------------|
| ZS8          | 2.1          | 5.0               | 3/4"                  | 9" x 9" x 12"               | 1.5                     | 5038375           | \$502.00           |
| ZS12         | 3.2          | 8.0               | 3/4"                  | 11" x 11" x 11"             | 3.2                     | 5038498           | \$567.30           |
| ZS18         | 4.8          | 8.0               | 3/4"                  | 11" x 11" x 15"             | 3.3                     | 5043898           | \$960.68           |

## ULTRA INOX PRO – REPLACEABLE BLADDER MODELS

| Model Number | Volume (Gal) | Tank Weight (Lbs) | Connection Size (NPT) | Shipping Dimensions (LxWxH) | Acceptance Volume (Gal) | UPC Code (801985) | List Price (US \$) |
|--------------|--------------|-------------------|-----------------------|-----------------------------|-------------------------|-------------------|--------------------|
| ZS24V        | 6.3          | 10.0              | 1"                    | 12" x 13" x 20"             | 4.9                     | 5044796           | \$1,439.70         |
| ZS24H**      | 6.3          | 12.0              | 1"                    | 20" x 11" x 12"             | 4.9                     | 5039983           | \$1,552.14         |
| ZS60V**      | 15.9         | 30.0              | 1"                    | 27" x 16" x 17"             | 12.3                    | 5043348           | \$3,030.36         |
| ZS60H**      | 15.9         | 29.0              | 1"                    | 27" x 16" x 17"             | 12.3                    | 5044772           | \$3,067.56         |
| ZS100V**     | 26.4         | 39.0              | 1"                    | 32" x 19" x 20"             | 20.4                    | 5039631           | \$4,645.54         |
| ZS100H**     | 26.4         | 39.0              | 1"                    | 32" x 19" x 20"             | 20.4                    | 5044789           | \$4,670.04         |

\*Vertical \*\*Horizontal \* Includes welded pump bracket

| INOX PRO Operating Conditions                |                |
|--|----------------|
| max. operating pressure (ZS160)              | 220 PSIG       |
| max. operating pressure (ZS05-ZS18)          | 150 PSIG       |
| operating temperature                        | 14° F - 210° F |
| factory precharge up to .53 gal. (ZS150-ZS2) | 50 PSIG        |
| factory precharge 2.1-4.8 gal. (ZS8-ZS18)    | 36 PSIG        |
| diaphragm                                    | buytl          |
| warranty                                     | 5 years        |

| ULTRA INOX PRO Operating Conditions |                |
|-------------------------------------|----------------|
| max. operating pressure             | 150 PSIG       |
| operating temperature               | 14° F - 210° F |
| factory precharge                   | 22 PSIG        |
| replaceable bladder                 | butyl          |
| warranty                            | 5 years        |

**SEE OUR WEBSITE FOR TANK SIZING CALCULATOR** - Please see page 12 for tank accessories

# ZILMET ActivFlo



The ActivFlo is a No-Salt Hard Water Conditioner. Hard water is a common condition that is a result of calcium and magnesium in the water supply. Effects of hard water include limescale buildup, reduced water flow, reduced heating efficiency, and waste of detergents. The ActivFlo imposes a catalytic action as water flows through that causes calcium to form into an insoluble aragonite crystal. These crystals do not have the same bonding properties as calcium which means they won't stick to pipework, heating elements, faucets, etc.

**NOTES:**

- Maximum Operating Temperature: 210° F
- Maximum Operating Pressure: 232 PSIG (150 PSIG for ZAF012MF)
- Material: Stainless Steel
- NSF STD61 Certified (Residential Models)
- Massachusetts PHCC Listed
- Massachusetts Code Accepted

## RESIDENTIAL

| Model Number | Description              | Flowrate (GPM) | Connection Size | Body Length (In) | Weight (Lbs) | Carton Dimensions (LxWxH) | UPC Code      | List Price (US \$) |
|--------------|--------------------------|----------------|-----------------|------------------|--------------|---------------------------|---------------|--------------------|
| ZAFNANO      | Nano Low Flow 3/8"       | Up to 2.9      | 3/8" MNPT       | 3.6"             | 0.4          | 3.5" x 1" x 1"            | 5055143777215 | \$535.71           |
| ZAF012MF     | SOLO Point-of-Use 1/2"   | 0.7 - 3.6      | 1/2" M/F NPT    | 3.8"             | 0.6          | 4" x 1.25" x 1.25"        | 5055143770926 | \$910.98           |
| ZAF034       | Residential 3/4"         | 1.9 - 5.9      | 3/4" MNPT       | 6.0"             | 1.0          | 9" x 9" x 2"              | 5055143768985 | \$2,869.70         |
| ZAF010       | Residential 1"           | 1.9 - 5.9      | 1" MNPT         | 7.3"             | 2.2          | 9" x 9" x 2"              | 5055143768978 | \$2,929.70         |
| ZAF010H      | Residential High Flow 1" | 5.9 - 15.9     | 1" MNPT         | 8.3"             | 2.0          | 9" x 9" x 2"              | 5055143768961 | \$3,475.00         |

## COMMERCIAL

| Model Number | Description           | Flowrate (GPM) | Connection Size | Body Length (In) | Weight (Lbs) | Carton Dimensions (LxWxH) | UPC Code      | List Price (US \$) |
|--------------|-----------------------|----------------|-----------------|------------------|--------------|---------------------------|---------------|--------------------|
| ZAF0114      | Commercial NPT 1-1/4" | 15.9 - 31.0    | 1-1/4" MNPT     | 21.6"            | 6.4          | CALL                      | 5055143770612 | \$8,251.38         |
| ZAF0112      | Commercial NPT 1-1/2" | 31.0 - 45.0    | 1-1/2" MNPT     | 21.6"            | 7.5          | CALL                      | 5055143770605 | \$10,237.89        |
| ZAF002       | Commercial NPT 2"     | 45.0 - 70.0    | 2" MNPT         | 21.6"            | 8.6          | CALL                      | 5055143770629 | \$13,358.41        |
| ZAF0025      | Commercial NPT 2-1/2" | 70.0 - 92.0    | 2-1/2" MNPT     | 28.0"            | 16.5         | CALL                      | 5055143770636 | \$32,544.38        |

## COMMERCIAL FLANGED

| Model Number | Description           | Flowrate (GPM) | Connection Size | Body Length (In) | Weight (Lbs) | Carton Dimensions (LxWxH) | UPC Code      | List Price (US \$) |
|--------------|-----------------------|----------------|-----------------|------------------|--------------|---------------------------|---------------|--------------------|
| ZAF003       | Commercial Flanged 3" | 92.0 - 181.0   | 3" Flanged      | 33.5"            | 44.0         | CALL                      | 5055143770643 | \$46,104.56        |
| ZAF004       | Commercial Flanged 4" | 181.0 - 333.0  | 4" Flanged      | 33.5"            | 55.0         | CALL                      | 5055173770650 | \$75,123.25        |
| ZAF005       | Commercial Flanged 5" | 333.0 - 482.0  | 5" Flanged      | 33.5"            | 77.0         | CALL                      | 5055143770667 | \$105,091.25       |
| ZAF006       | Commercial Flanged 6" | 482.0 - 925.0  | 6" Flanged      | 33.5"            | 86.9         | CALL                      | 5055143770674 | \$142,381.66       |

[SEE OUR WEBSITE FOR TANK SIZING CALCULATOR](#)



# ZILMET ActivFlo Lite



The ActivFlo Lite is a Point of Use (POU) water conditioner is used to protect all appliances and water heaters from scaling issues

**NOTES:**

Maximum Operating Temperature: 210

Material: Stainless Steel

Massachusetts PHCC Listed

12 Year Warranty



| Model Number | Description            | Optimal Flowrate (GPM) | Connection Size | Body Length (In) | Weight (Lbs) | Carton Dimensions (LxWxH) | UPC Code      | List Price (US \$) |
|--------------|------------------------|------------------------|-----------------|------------------|--------------|---------------------------|---------------|--------------------|
| ZAFL2234     | Lite Point-of-Use 3/4" | 0 – 12.4               | 3/4" FNPT       | 8.1"             | 1.6          | 9" x 2" x 2"              | 5055143774795 | \$715.00           |

For use with traditional water heaters and tankless water heaters.

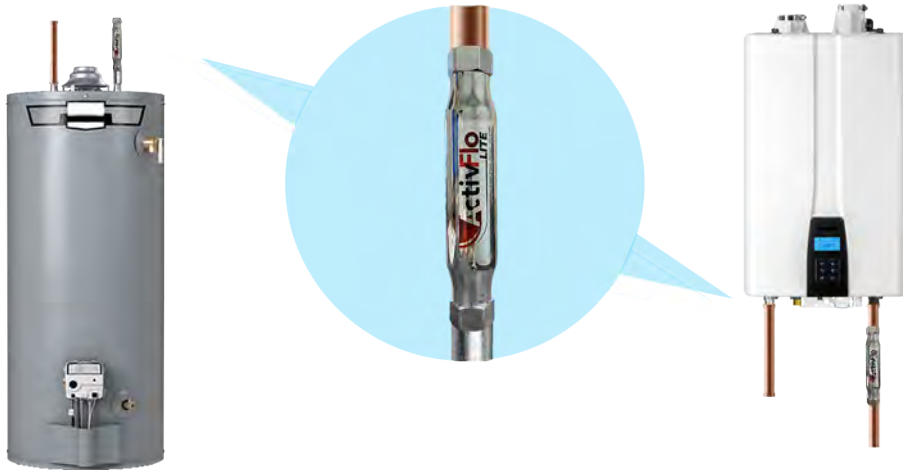

Free ActivFlo Lite counter display box with every purchase of 10 or more!



SCAN FOR MORE INFORMATION ON THE ACTIVFLO WATER CONDITIONER

# ZILMET Maximizer



ASSE 1017  
Certified



Certified to  
NSF/ANSI 61 & 372



PLUMBING-HEATING-COOLING  
CONTRACTORS ASSOCIATION

The Maximizer is installed on a water heater and will allow the water heater to safely operate at a higher set point. Two advantages are: (1) more useable hot water from your water heater, (2) higher temperatures kill water-borne bacteria.

**NOTES:**

Temperature Adjustment Range: 95-140 °F  
 Factory Preset Temperature: 120°F  
 Maximum Inlet Temperature: 195°F

Maximum Inlet Pressure: 150 PSIG  
 Maximum Inlet Pressure (dynamic): 75 PSIG  
 Minimum Flow Rate Requirement: 1.2 gpm  
 Meets ASSE1070 ASME A112.1070 / CSA B125.70  
 Meets ASSE1017 CSA B125.70  
 NSF/ANSI 372 Certified  
 NSF/ANSI STD61 Certified  
 Massachusetts PHCC listed  
*To estimate hot water gained, see our Zilmet Tank Calculator on our website.*

| Model Number  | Description  | Flowrate (GPM) | Connection Size | Body Length (In) | Weight (Lbs) | Shipping Dimensions (LxWxH) | List Price (US \$) |
|---------------|--|----------------|-----------------|------------------|--------------|-----------------------------|--------------------|
| ZMIX ZTM7550G | Zilmet Thermostatic Mixing Valve 3/4" NPT Connection | 1.2-11.0 GPM   | 3/4" NPT        | 7.75"            | 4.2          | 10" x 8" x 4"               | \$425.95           |

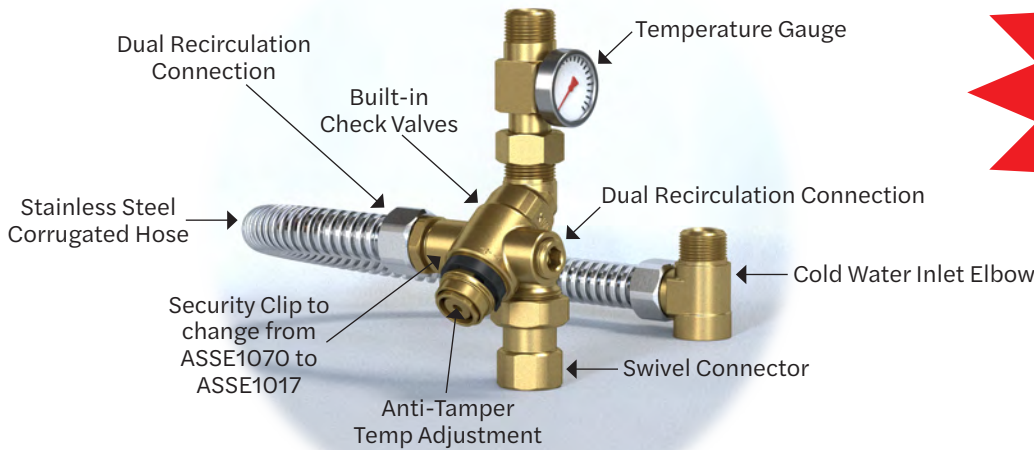

# ZILMET Cal Pro (ZHT) Hydronic Expansion Tanks



Side connection allows for quicker, less expensive installation



Side connection on stand models only.

## IN LINE MODELS

| Model Number | Volume (Gal) | Tank Weight (Lbs) | Connection Size (NPT) | Shipping Dimensions (LxWxH) | Acceptance Volume (Gal) | UPC Code (801985) | List Price (US \$) |
|--------------|--------------|-------------------|-----------------------|-----------------------------|-------------------------|-------------------|--------------------|
| ZHT8-15      | 2.1          | 5.0               | 1/2"                  | 9" x 9" x 13"               | 1.4                     | 5046172           | \$126.00           |
| ZHT18-30     | 4.8          | 9.0               | 1/2"                  | 12" x 12" x 16"             | 3.3                     | 5039860           | \$157.50           |
| ZHT24-60     | 6.3          | 12.0              | 1/2"                  | 13" x 13" x 17"             | 3.9                     | 5038283           | \$288.54           |
| ZHT35        | 9.2          | 18.0              | 3/4"                  | 16" x 16" x 17"             | 5.7                     | 5039877           | \$353.06           |
| ZHT50-90     | 13.2         | 22.0              | 3/4"                  | 16" x 16" x 22"             | 8.1                     | 5038290           | \$429.50           |

## STAND MODELS

| Model Number | Volume (Gal) | Tank Weight (Lbs) | Connection Size (NPT) | Shipping Dimensions (LxWxH) | Acceptance Volume (Gal) | UPC Code (801985) | List Price (US \$) |
|--------------|--------------|-------------------|-----------------------|-----------------------------|-------------------------|-------------------|--------------------|
| ZHT35F       | 9.2          | 18.0              | 3/4"                  | 16" x 16" x 17"             | 5.7                     | 5042297           | \$ 387.66          |
| ZHT50F       | 13.2         | 22.0              | 3/4"                  | 16" x 16" x 22"             | 8.1                     | 5042303           | \$482.58           |
| ZHT80        | 21.1         | 30.0              | 3/4"                  | 18" x 18" x 25"             | 15.3                    | 5038603           | \$611.36           |
| ZHT105       | 27.7         | 44.0              | 3/4"                  | 20" x 20" x 27"             | 20.1                    | 5039839           | \$949.88           |
| ZHT150       | 39.6         | 47.0              | 3/4"                  | 20" x 20" x 37"             | 28.8                    | 5039846           | \$1,206.50         |
| ZHT200       | 52.8         | 55.0              | 3/4"                  | 24" x 24" x 33"             | 38.4                    | 5039884           | \$1,497.46         |
| ZHT250       | 66.0         | 86.0              | 3/4"                  | 25" x 25" x 40"             | 48.0                    | 5039891           | \$1,739.38         |
| ZHT300       | 79.3         | 112.0             | 3/4"                  | 26" x 26" x 46"             | 57.7                    | 5039907           | \$2,225.24         |
| ZHT400       | 105.7        | 131.0             | 3/4"                  | 26" x 26" x 61"             | 76.8                    | 5038740           | \$ 3,065.16        |
| ZHT500       | 132.1        | 162.0             | 1"                    | 30" x 30" x 55"             | 96.0                    | 5039914           | \$3,865.94         |
| ZHT600       | 158.5        | 178.0             | 1"                    | 30" x 30" x 62"             | 115.2                   | 5038757           | \$4,494.00         |
| ZHT700       | 184.9        | 196.0             | 1"                    | 30" x 30" x 70"             | 134.2                   | 5039921           | \$5,996.60         |

| Description | Material             |
|-------------|----------------------|
| shell       | carbon steel         |
| connection  | carbon steel         |
| diaphragm   | SBR synthetic rubber |
| color       | grey                 |

For Hydronic Use Only

| Operating Conditions                       |         |
|--|---------|
| max. operating pressure (2.1 gal)          | 75 PSIG |
| max. operating pressure (4.8 - 13.2 gal)   | 60 PSIG |
| max. operating pressure (21.1 - 184.9 gal) | 90 PSIG |
| max. operating temperature                 | 210° F  |
| factory precharge                          | 12 PSIG |
| warranty                                   | 5 years |

[SEE OUR WEBSITE FOR TANK SIZING CALCULATOR](#)

# ZILMET Specialty Hydronic Tanks

## ZILMET FLATS (ZFT) FLAT HYDRONIC EXPANSION TANKS



The Space Saving Expansion



All tanks come with a fixed mounting bracket and a union connection with a two way service check valve

| Model Number | Volume (Gal)                                | Tank Weight (Lbs) | Connection Size (NPT) | Shipping Dimensions (LxWxH) | Acceptance Volume (Gal) | UPC Code (801985) | List Price (US \$) |
|--------------|---|-------------------|-----------------------|-----------------------------|-------------------------|-------------------|--------------------|
| ZFT8C-15 *   | 2.1   | 12.0              | 1/2"                  | 16" x 16" x 5"              | 1.1                     | 5042501           | \$243.58           |
| ZFT18C-30*   | 4.8   | 15.0              | 1/2"                  | 16" x 16" x 9"              | 2.4                     | 5042594           | \$279.48           |
| ZFT8R-15**   | 2.1   | 11.0              | 1/2"                  | 20" x 11" x 5"              | 1.1                     | 5042587           | \$269.28           |
| ZFT18R-30**  | 4.8   | 20.0              | 1/2"                  | 20" x 15" x 7"              | 2.7                     | 5042600           | \$440.64           |
| ZFT24R-60**  | 6.3   | 22.0              | 1/2"                  | 20" x 15" x 8"              | 3.9                     | 5050322           | \$560.48           |
| ZFT-U        | Union connection with a two way check valve |                   |                       |                             |                         |                   | \$64.00            |

\* Circular hydronic tank with union and mounting bracket

\*\* Rectangular hydronic tank with union and mounting bracket

| Operating Conditions                       |           |
|--|-----------|
| factory precharge                          | 12 PSIG   |
| max. working pressure ZFT8C, ZFT18C, ZFT8R | 43.5 PSIG |
| max. working pressure ZFT18R, ZFT24R       | 51 PSIG   |
| max. operating temperature                 | 194 °F    |
| color                                      | gray      |
| warranty                                   | 5 years   |



**ZFT-U:**  
Union connection with a two way check valve.

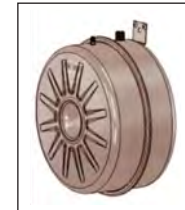

Hanging Bracket

**Tank union works on all 1/2" in line hydronic expansion tanks**

For Hydronic Use Only

## ZILMET CAL PRO (ZHT) IN-LINE HYDRONIC RADIANT TANKS

| Model Number | Volume (Gal) | Tank Weight (Lbs) | Connection Size (NPT) | Shipping Dimensions (LxWxH) | Acceptance Volume (Gal) | UPC Code (801985) | List Price (US \$) |
|--------------|--------------|-------------------|-----------------------|-----------------------------|-------------------------|-------------------|--------------------|
| ZHT-R15      | 2.1          | 5.0               | 1/2"                  | 8" x 8" x 11"               | 1.4                     | 5051725           | \$221.52           |
| ZHT-R30      | 4.8          | 10.0              | 1/2"                  | 11" x 11" x 14"             | 3.3                     | 5051732           | \$248.40           |

| Description | Material        |
|-------------|-----------------|
| shell       | carbon steel    |
| connection  | stainless steel |
| diaphragm   | butyl           |
| color       | grey            |

| Operating Conditions    |          |
|-------------------------|----------|
| max. operating pressure | 150 PSIG |
| operating temperature   | 210° F   |
| factory precharge       | 12 PSIG  |
| warranty                | 5 years  |

For Hydronic Use Only



- TECHNICAL FEATURES:**
- Designed for low temperature radiant floor systems
  - All radiant tanks have a polypropylene liner to prevent corrosion due to oxygen entering the system
  - All tanks come with a stainless steel connector
  - Suitable for use with glycol

[SEE OUR WEBSITE FOR TANK SIZING CALCULATOR](#)

# ZILMET Ultra Pro (ZUP) Potable Tanks with Replaceable Bladder



- These tanks offer unlimited service as the bladder is easily replaceable
- A full range of replaceable bladder expansion tanks ranging from 2 gallons up to 260 gallons

## VERTICAL MODELS

| Model Number | Volume (Gal) | Tank Weight (Lbs) | Connection Size (NPT) | Shipping Dimensions (LxWxH) | Acceptance Volume (Gal) | UPC Code (801985) | List Price (US \$) |
|--------------|--------------|-------------------|-----------------------|-----------------------------|-------------------------|-------------------|--------------------|
| ZUP8         | 2.1          | 2.6               | 3/4"                  | 13.8" x 8.1" x 8.3"         | 1.5                     | 5041566           | \$69.06            |
| ZUP12V       | 3.2          | 3.2               | 3/4"                  | 11" x 12.6" x 11.1"         | 2.4                     | 5041573           | \$76.02            |
| ZUP18V       | 5            | 3.8               | 3/4"                  | 10.9" x 16.5" x 11"         | 3.7                     | 5041580           | \$85.14            |
| ZUP24V       | 6.3          | 5.3               | 1"                    | 19.4" x 11" x 11.3"         | 4.6                     | 5041597           | \$90.36            |
| ZUP50V       | 13.2         | 9.9               | 1"                    | 15.2" x 15.2" x 30.9"       | 9.7                     | 5040668           | \$313.14           |
| ZUP60V*      | 15.9         | 10.2              | 1"                    | 15.4" x 15.8" x 34.3"       | 11.7                    | 5041610           | \$327.78           |
| ZUP80V*      | 21.1         | 11.6              | 1"                    | 18.1" x 18.1" x 32.9"       | 15.5                    | 5040767           | \$397.56           |
| ZUP100V*     | 26.4         | 15.8              | 1"                    | 18.1" x 18.4" x 38.2"       | 19.4                    | 5041641           | \$510.60           |
| ZUP200V*     | 52.8         | 36.5              | 1 1/2"                | 20.9" x 22.9" x 51.3"       | 38.8                    | 5042013           | \$836.94           |
| ZUP300V*     | 79.3         | 51.0              | 1 1/2"                | 24.8" x 24.8" x 55.7"       | 58.3                    | 5042006           | \$1,048.34         |
| ZUP500V*     | 132.1        | 79.7              | 1 1/2"                | 29.5" x 29.5" x 63.4"       | 97.2                    | 5046462           | \$1,722.72         |
| ZUP750V*     | 198.1        | 142.7             | 1 1/2"                | 29.5" x 29.5" x 83.7"       | 134.0                   | 5046448           | \$3,110.64         |
| ZUP1000*     | 264.2        | 208.7"            | 1 1/2"                | 33.5" x 33.5" x 84.6"       | 154.2                   | 5040491           | \$6,263.88         |

## HORIZONTAL MODELS

| Model Number | Volume (Gal) | Tank Weight (Lbs) | Connection Size (NPT) | Shipping Dimensions (LxWxH) | Acceptance Volume (Gal) | UPC Code (801985) | List Price (US \$) |
|--------------|--------------|-------------------|-----------------------|-----------------------------|-------------------------|-------------------|--------------------|
| ZUP24H*      | 6.3          | 5.3               | 1"                    | 10.6" x 11.4" x 19.1"       | 4.6                     | 5038337           | \$111.00           |
| ZUP50H*      | 13.2         | 9.9               | 1"                    | 15" x 16.1" x 22.1"         | 9.7                     | 5038306           | \$313.14           |
| ZUP60H*      | 15.9         | 10.2              | 1"                    | 15" x 16.1" x 25.2"         | 11.7                    | 5038214           | \$327.78           |
| ZUP80H*      | 21.1         | 11.6              | 1"                    | 17.7" x 18.9" x 25.2"       | 15.5                    | 5038221           | \$397.56           |
| ZUP100H*     | 26.4         | 15.8              | 1"                    | 17.7" x 18.9" x 28.7"       | 19.4                    | 5038238           | \$510.60           |
| ZUP200H*     | 52.8         | 36.5              | 1 1/2"                | 21.7" x 22.8" x 38.8"       | 38.8                    | 5038245           | \$836.94           |
| ZUP300H*     | 79.3         | 51.0              | 1 1/2"                | 24.8" x 26" x 44.9"         | 58.3                    | 5041542           | \$1,060.14         |

\*Welded pump bracket

| Description    |  | Material     | Operating Conditions       |          |
|----------------|--|--------------|----------------------------|----------|
| shell          |  | carbon steel | factory precharge          | 28 PSIG  |
| connections    |  | carbon steel | max. working pressure      | 150 PSIG |
| fixed membrane |  | butyl        | max. operating temperature | 210° F   |
| color          |  | blue         | warranty                   | 5 years  |

SEE OUR WEBSITE FOR TANK SIZING CALCULATOR

# ZILMET Expansion Tank Accessories

## TANK T KITS



### ZTK-1

- ZILMET Tank T Kit – No Lead
  - Tank T Fitting Package with ZTT -1 for 1" connection.
- List Price: \$230.68

### ZTK-2

- ZILMET Tank T Kit – No Lead
  - Tank T Fitting Package with ZTT -2 for 1 1/4" connection.
- List Price: \$268.68

### PACKAGE CONTAINS

- No Lead Brass Tank T with Swivel Union Nut
- 40/60 Pressure Switch
- No Lead Pressure Gauge 0-100 PSIG
- 1/4" NPT X 3" No Lead Brass Nipple
- 1/2 NPT No Lead Brass Boiler Drain with Hose Bibb
- 1/2" No Lead Pressure Relief Valve

| ULTRA PRO/INOX PRO-REPLACEMENT MEMBRANES          | LIST PRICE (US \$) |
|---|--------------------|
| Replacement membrane for 24L Ultra Pro Tank       | \$341.80           |
| Replacement membrane for 60-80L Ultra Pro Tank    | \$385.20           |
| Replacement membrane for 100L Ultra Pro Tank      | \$424.40           |
| Replacement membrane for 200L Ultra Pro Tank      | \$786.00           |
| Replacement membrane for 300L Ultra Pro Tank      | \$980.80           |
| Replacement membrane for 500L Ultra Pro Tank      | \$1,598.24         |
| Replacement membrane for 750-1000L Ultra Pro Tank | \$1,960.60         |

## TANK T UNION



**ZTT-1**  
1" connection size  
List Price: \$98.00



**ZTT-2**  
1 1/4" connection size  
List Price: \$137.20



## STAINLESS STEEL FLEX CONNECTORS



Our new connector allows for easier and faster installation in tank replacement applications.

| Model Number | Length | Item Weight (Lbs) | Connections       | List Price (US \$) |
|--------------|--------|-------------------|-------------------|--------------------|
| ZFLEX 1-12   | 12"    | .40               | 1" NPT female     | \$78.70            |
| ZFLEX 1-18   | 18"    | .40               | 1" NPT female     | \$84.30            |
| ZFLEX 2-18   | 18"    | .60               | 1 1/4" NPT female | \$50.02            |

- Max working pressure: 125 PSIG
- Max working temp: 240 °F
- UPC Certified
- AB 1953 Compliant
- Complies with NSF61
- Meets ASME A112.18.6

## MOUNTING BRACKETS FOR TANKS UP TO 6.3 GAL



**ZWH B** \$78.70



**ZWH HP** \$84.30

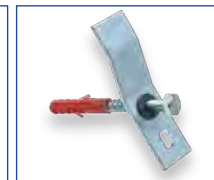

**ZWH M** \$50.02

## UNION CONNECTION



Union connection with a two way check valve for hydronic use only

**ZFT-U** \$64.00

[SEE OUR WEBSITE FOR TANK SIZING CALCULATOR](#)

# ZILMET Zil-Kit Boiler Trim Kit Package

This kit enables the installer to carry the essential components for a heating system in one compact carton.

Available in NPT and SWT connections

The Assembly Includes

- 4.8 gal hydronic expansion tank
- Microbubble deaerator
- Multi isolation valve
- Backflow prevention device
- Boiler fill valve with pressure gauge
- Brass connector nipples (2)

## FEATURES AND BENEFITS

- 4.8 gal hydronic expansion tank included in package
- NPT and SWT connections
- All in one package solution
- Multi isolation valve
- Drain off outlet for easy system servicing
- Microbubble deaerator
- For use with up to 50% glycol



## PRODUCT RANGE AND DIMENSIONS

| Model Number | Weight (Lbs) | Connection Size | Shipping Dimensions (LxWxH) | UPC Code (801985) | List Price (US \$) |
|--------------|--------------|-----------------|-----------------------------|-------------------|--------------------|
| ZBTK01N      | 18.0         | ¾" NPT          | 12.5" x 12.5" x 22"         | 5055181           | \$1,320.00         |
| ZBTK02N      | 18.0         | 1" NPT          | 12.5" x 12.5" x 22"         | 5055198           | \$1,400.00         |
| ZBTK03N      | 18.0         | 1 ¼" NPT        | 12.5" x 12.5" x 22"         | 5055204           | \$1,480.00         |
| ZBTK01S      | 18.0         | ¾" SWT          | 12.5" x 12.5" x 22"         | 5055211           | \$1,400.00         |
| ZBTK02S      | 18.0         | 1" SWT          | 12.5" x 12.5" x 22"         | 5055228           | \$1,480.00         |
| ZBTK03S      | 18.0         | 1 ¼" SWT        | 12.5" x 12.5" x 22"         | 5055235           | \$1,560.00         |
| ZBTK02P      | 18.2         | 1" Press        | 12.5" x 12.5" x 22"         | 55080893          | \$1,477.00         |
| ZBTK03P      | 18.2         | 1 ¼" Press      | 12.5" x 12.5" x 22"         | 55080909          | \$1,490.00         |

Boiler Trim Kit and Accessories for Hydronic Use Only

[SEE OUR WEBSITE FOR TANK SIZING CALCULATOR](#)

# ZILMET Boiler Accessories

## MICROBUBBLE DEAERATOR

ZILMET Microbubble Deaerator is designed to vent trapped air within sealed systems at pressures up to 150 PSIG. This helps to maintain optimum system efficiency, improves energy usage, reduces system corrosion, eliminates noise from system pipe work and helps to extend the working life of system heat pumps.



| Model Number | Product Range Description | UPC Code (505514) | List Price (US \$) |
|--------------|---------------------------|-------------------|--------------------|
| ZU0001       | 3/4" NPT                  | 3759273           | \$480.00           |
| ZU0002       | 1" NPT                    | 3759280           | \$528.00           |
| ZU0003       | 1 1/4" NPT                | 3759297           | \$760.00           |
| ZU0004       | 3/4" SWT                  | 3759303           | \$512.00           |
| ZU0005       | 1" SWT                    | 3759310           | \$552.00           |
| ZU0006       | 1 1/4" SWT                | 3759327           | \$870.00           |

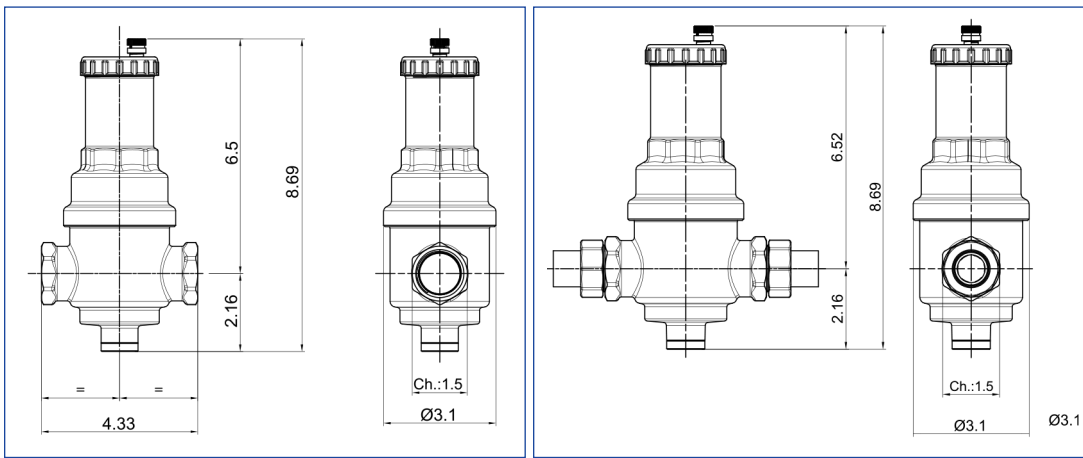

## BOILER FILL VALVE

ZILMET Boiler Fill Valve is a crucial part of a boiler trim kit. Designed as an automatic filling unit which reintegrates fluid into the closed systems in the event of lost fluid deaeration (process produces steam/gas mixture that develops continuously in closed looped heating circuits.)

## FEATURES AND BENEFITS

- Isolation valve standard
- Easy to use "dial up" adjustment head
- Internal check valve prevents the return of potentially contaminated fluid

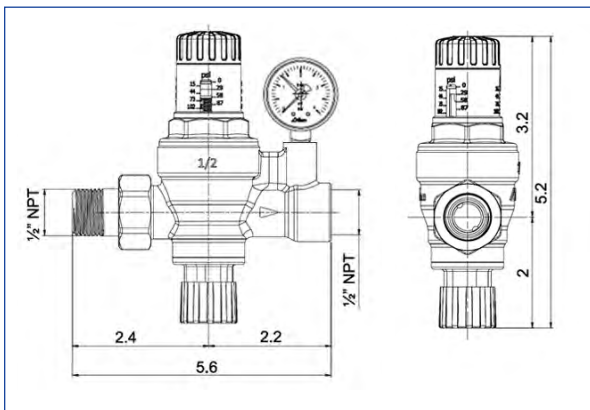

| Model Number | Product Range Description | UPC Code (505514) | List Price (US \$) |
|--------------|---------------------------|-------------------|--------------------|
| ZU0007       | 1/2" Boiler Fill Valve    | 3759334           | \$306.00           |

| Operating Conditions    | Boiler Fill Valve | Microbubble Deaerator        |
|-------------------------|-------------------|------------------------------|
| max. operating pressure | 150 PSIG          | 150 PSIG                     |
| max. temperature        | 230° F            | 230° F                       |
| inlet connections       | 1/2" NPT          | 3/4" NPT, 1" NPT, 1 1/4" NPT |
| adjustment range        | 7.5 to 100 PSIG   | 3/4" SWT, 1" SWT, 1 1/4" SWT |

Boiler Trim Kit and Accessories for Hydronic Use Only

[SEE OUR WEBSITE FOR TANK SIZING CALCULATOR](#)





## BACKFLOW PREVENTION DEVICE

The ZILMET Backflow Prevention Device is designed to prevent potentially polluted heating system fluid back flowing into the domestic water system



## FEATURES AND BENEFITS

- Drainage point to visibly identify system operating faults
- Internal stainless steel filter
- NPT or SWT connection options available
- Robust brass construction

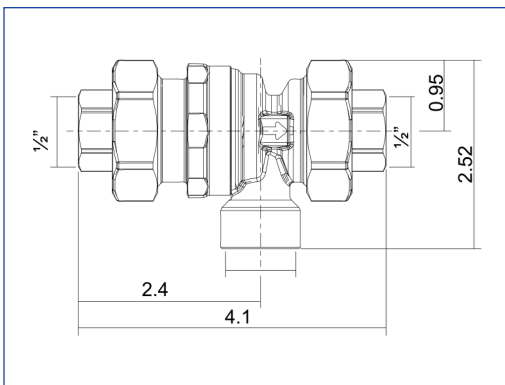

| Model Number | Product Range Description           | UPC Code (505514) | List Price (US \$) |
|--------------|-------------------------------------|-------------------|--------------------|
| ZU0008       | 1/2" Backflow Prevention Device NPT | 3759341           | \$252.80           |
| ZU0009       | 1/2" Backflow Prevention Device SWT | 3759358           | \$270.40           |

| Operating Conditions    |                    |
|-------------------------|--------------------|
| max. operating pressure | 175 PSIG           |
| max. temperature        | 32° F to 210° F    |
| inlet connections       | 1/2" NPT, 1/2" SWT |

## MULTI ISOLATION VALVE

ZILMET Multi Isolation Valve is the ultimate valve for complete fluid control. The valve allows complete isolation for the inlet flow, expansion vessel and live system providing the ideal component for boiler trim kit assemblies



## FEATURES AND BENEFITS

- System pressure gauge supplied as standard
- Multiple isolation points
- Anti-tamper locking handle
- Drain port as standard

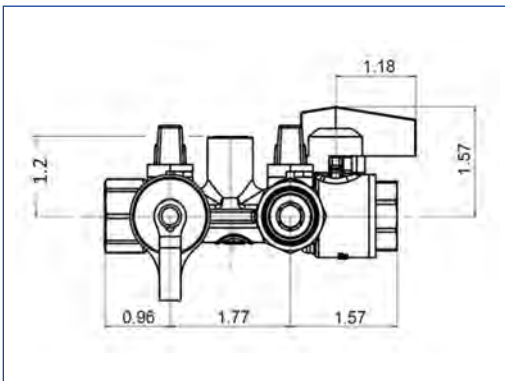

| Model Number | Product Range Description      | UPC Code (505514) | List Price (US \$) |
|--------------|--------------------------------|-------------------|--------------------|
| ZU0020       | 1/2" NPT Multi Isolation Valve | 3759372           | \$232.00           |

| Operating Conditions    |          |
|-------------------------|----------|
| max. operating pressure | 150 PSIG |

# ZILMET IntaKlean2 Multifunction Magnetic Dirt Separator Filter



## intaKlean<sup>2</sup>

### MULTIFUNCTION MAGNETIC DIRT SEPARATOR FILTER FOR HYDRAULIC CIRCUITS

ZILMET IntaKlean is the best solution in solving plant problems due to the presence of particles caused by corrosion and scale during normal system operation. The magnetic filter effectively collects all the impurities present in the circuit and prevents them from circulating within it. All the magnetic contaminants (ferrous residues) and non-magnetic (algae, sludge, sand etc.) are then easily removed by simply opening the drain plug. The device protects the boiler continuously, avoiding wear and damage of all system components.



### TECHNICAL FEATURES:

- It can be mounted on vertical, horizontal and diagonal piping
- All impurities are removed helping to increase the working life of the boiler
- Maintains optimum system efficiency by fighting corrosion
- Easy to clean
- Easy 16.6 ounce dosing of the treatment fluids
- 5 year manufacturer's warranty
- 12,000 gauss magnet strength

### PRODUCT RANGE AND DIMENSIONS

| Model Number | Weight (Lbs) | Connection Size (NPT) | Shipping Dimensions (LxWxH) | C (In) | D (In) | E (In) | UPC Code      | List Price (US \$) |
|--------------|--------------|-----------------------|-----------------------------|--------|--------|--------|---------------|--------------------|
| IK203        | 5.0          | ¾"                    | 12" x 12" x 8"              | 9.4"   | 7.5"   | 6.1"   | 5055143758801 | \$640.00           |
| IK210        | 5.0          | 1"                    | 12" x 12" x 8"              | 10.5"  | 7.5"   | 6.1"   | 5055143758818 | \$810.00           |
| IK211        | 5.0          | 1 ¼"                  | 12" x 12" x 8"              | 10.5"  | 7.5"   | 6.1"   | 5055143758825 | \$875.60           |
| IK210-P      | 6.6          | 1" Press              | 12" x 12" x 8"              | 13.5"  | 7.5"   | 6.1"   | 8019855079972 | \$943.40           |
| IK211-P      | 6.6          | 1 ¼" Press            | 12" x 12" x 8"              | 14.3"  | 7.5"   | 6.1"   | 3760208671477 | \$1,060.83         |

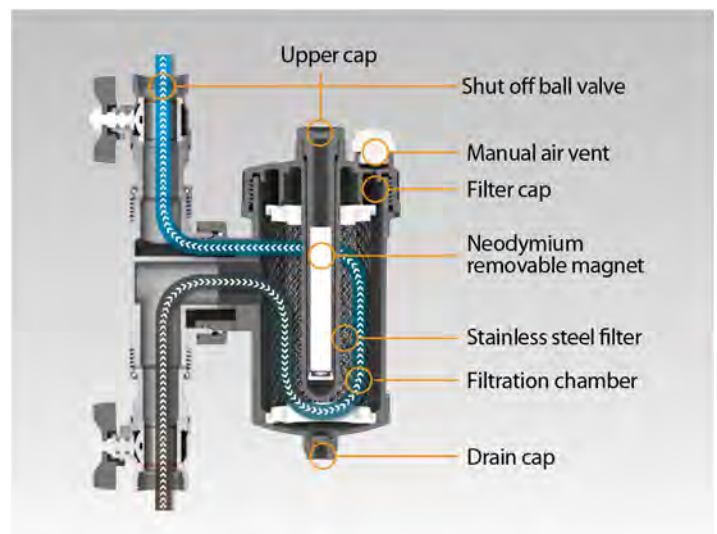
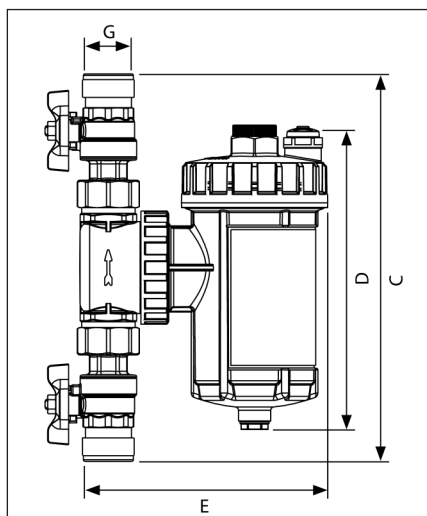

For Hydronic Use Only

[SEE OUR WEBSITE FOR TANK SIZING CALCULATOR](#)

# ZILMET MAG PRO

## Magnetic Systems Hub

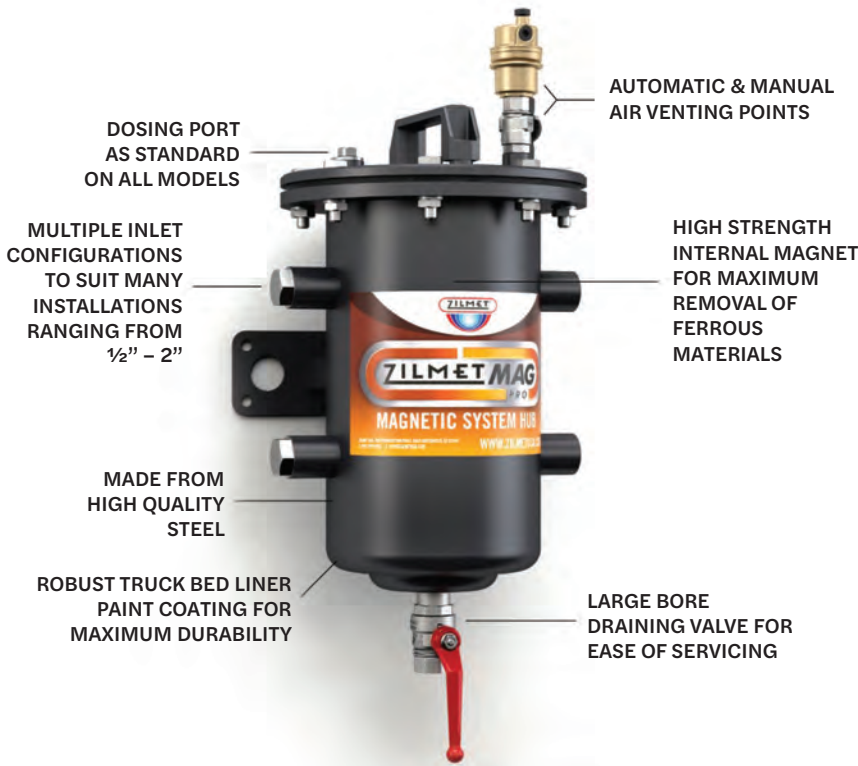

### TECHNICAL FEATURES

- Various inlet connection sizes ranging from 1/2" NPT to 2" NPT
- Quick and efficient servicing schedule
- Self closing filter basket for easy debris removal
- Multiple inlet configurations to suit many installations
- Manual and automatic air venting
- Mesh particle filtration down to 1 Microns
- 5 year manufacturer's warranty

### ZILMET MAG

| Model Number | Weight (Lbs) | Connection Size (NPT) | Shipping Dimensions (LxWxH) | List Price (US \$) |
|--------------|--------------|-----------------------|-----------------------------|--------------------|
| ZM02         | 39.0         | 1/2"                  | 19" x 13" x 12"             | \$2,652.00         |
| ZM03         | 39.0         | 3/4"                  | 19" x 13" x 12"             | \$2,796.00         |
| ZM10         | 39.0         | 1"                    | 19" x 13" x 12"             | \$2,928.00         |
| ZM11         | 39.0         | 1 1/4"                | 19" x 13" x 12"             | \$3,192.00         |
| ZM12         | 39.0         | 1 1/2"                | 19" x 13" x 12"             | \$3,632.00         |
| ZM20         | 39.0         | 2"                    | 19" x 13" x 12"             | \$3,968.00         |

| Technical Specification |          |
|-------------------------|----------|
| max. operating pressure | 145 PSIG |
| max. temperature        | 230° F   |
| degree of filtration    | 1 Micron |

### MICRON FILTER BAGS

| Model Number | Filter Bag Size | List Price (US \$) |
|--------------|-----------------|--------------------|
| IMPFB01      | 1 Micron        | \$684.46           |
| IMPFB05      | 5 Micron        | \$654.11           |
| IMPFB10      | 10 Micron       | \$623.57           |
| IMPFB20      | 20 Micron       | \$593.21           |
| IMPFB30      | 30 Micron       | \$593.21           |
| IMPFB50      | 50 Micron       | \$578.04           |



For Hydronic Use Only

[SEE OUR WEBSITE FOR TANK SIZING CALCULATOR](#)

# ZILMET MAG PRO PLUS

## Magnetic System Hub for Commercial and Industrial Systems

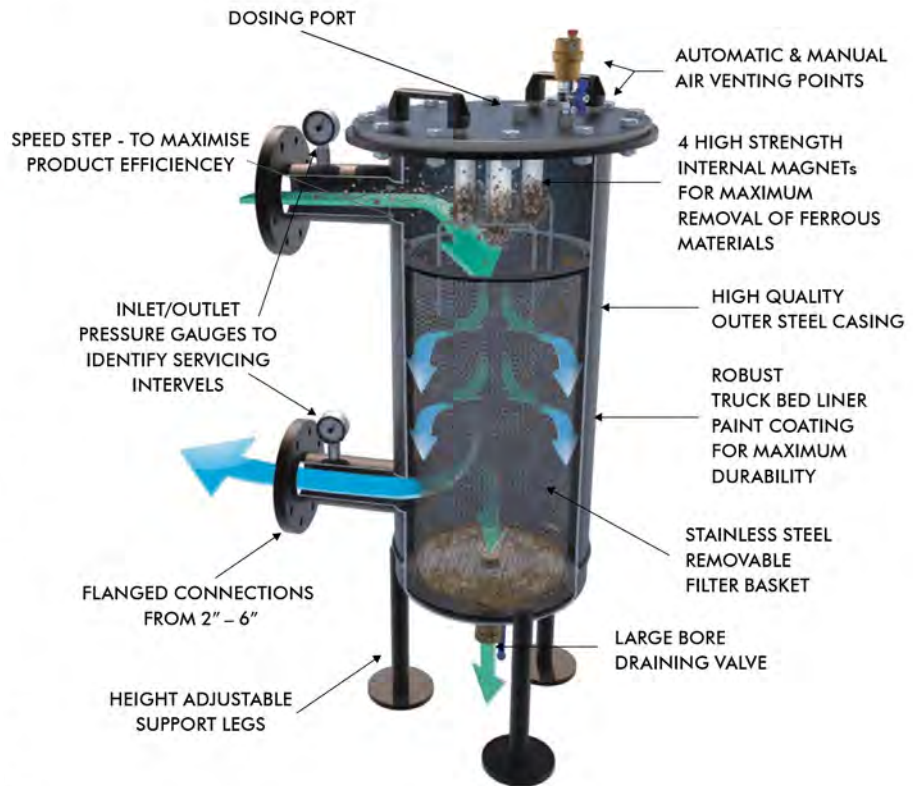

## ZILMET MAG PRO PLUS

| Model Number | Weight (Lbs) | Connection Size (NPT) | Shipping Dimensions (LxWxH) | List Price (US \$) |
|--------------|--------------|-----------------------|-----------------------------|--------------------|
| ZMPP20       | 115.0        | 2"                    | 44" x 18" x 23"             | \$9,512.00         |
| ZMPP22       | 115.0        | 2 1/2"                | 44" x 18" x 23"             | \$10,160.00        |
| ZMPP30       | 115.0        | 3"                    | 44" x 18" x 23"             | \$11,420.00        |
| ZMPP40       | 115.0        | 4"                    | 44" x 18" x 23"             | \$12,840.00        |
| ZMPP50       | 115.0        | 5"                    | 44" x 18" x 23"             | \$16,948.00        |
| ZMPP60       | 115.0        | 6"                    | 44" x 18" x 23"             | \$19,060.00        |

| Technical Specification |                  |
|-------------------------|------------------|
| max. operating pressure | 145 PSIG         |
| max. temperature        | 230° F           |
| inlet connection        | 2" to 6" Flanged |
| manufacturers warranty  | 5 years          |

For Hydronic Use Only

[SEE OUR WEBSITE FOR TANK SIZING CALCULATOR](#)

# ZILMET Plate and Frame Heat Exchanger

## GENERAL INFORMATION

- **Applications:** The ZILMET plate heat exchanger has many applications. These include: production of sanitary hot water, decoupling of thermal circuits, district heating systems, recovery of heat coming from industrial process, cooling or heating of alimentary fluids (milk, beer, wine, etc), cooling of industrial machineries, heating of water for swimming pools and solar systems.
- **Advantages:** In every situation which requires a thermal exchange between two fluids, ZILMET plate heat exchangers are the right choice. The high efficiency, the long life, the low price, the small dimensions, the high modularity, the easy maintenance and the high reliability are some of the most important advantages of ZILMET plate heat exchangers.



## TECHNICAL FEATURES

- **PLATES** The plates are manufactured with 316 L stainless steel .0197 inches thick. This kind of material and thickness allows a smooth and quick transition to assure great corrosion resistance.
- **GASKETS** ZILMET plate heat exchangers are equipped with glued EPDM gaskets with a maximum working temperature of 284° F for particular applications, such as gasoline and oils, they can be equipped on request with nitril glued gaskets, for a maximum working temperature of 230° F.
- **FRAMES** The frames are manufactured with silver painted carbon steel. The thickness is designed for the respective working pressure.

- **TESTS** 100% of ZILMET plate heat exchangers are tested before shipment at 1.5 times the maximum working pressure.
- **TITANIUM PLATE AND FRAME HEAT EXCHANGERS AVAILABLE UPON REQUEST**
- **CUSTOM HEAT EXCHANGERS ARE AVAILABLE UPON REQUEST. PLEASE CONTACT US FOR CUSTOM PRICING.**

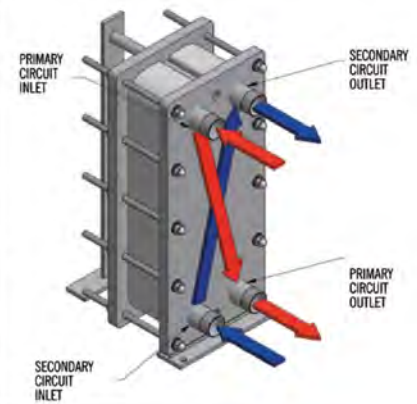
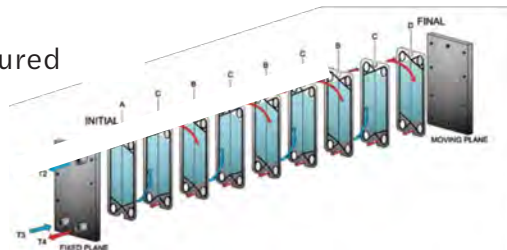

– Please call for sizing help and pricing [401.884.4943](tel:401.884.4943)

[SEE OUR WEBSITE FOR TANK SIZING CALCULATOR](#)

# ZILMET Plate and Frame Heat Exchanger

|  |                          |                   | Z2/10             | Z2/16              | Z3/10              | Z3/16              | Z4/16         |
|--|--------------------------|-------------------|-------------------|--------------------|--------------------|--------------------|---------------|
| <b>FRAME</b>   | Length                   | in                | 7.09              | 7.09               | 3.38               | 13.38              | 14.57         |
|  | Height                   | in                | 18.90             | 18.90              | 30.71              | 30.71              | 40.94         |
|  | Thickness                | in                | 0.47              | 0.55               | 0.98               | 1.18               | 1.38          |
| <b>PLATES</b>  | Exchange Surface         | in <sup>2</sup>   | 52.70             | 52.70              | 201.50             | 201.50             | 341.00        |
|  | Thickness                | in                | 0.02              | 0,02               | 0.02               | 0.02               | 0.02          |
| <b>TIE RODS</b>  | Length<br>(nr of plates) | in                | 4.72 (7-13)       | 4.72 (7-13)        | 13.78 (7-49)       | 13.78 (7-51)       | 19.68 (21-73) |
|  |                          |                   | 5.90 (15-21)      | 5.90 (15-21)       | 21.65 (51-75)      | 21.65 (53-75)      | 39.37 (>75)   |
|  |                          |                   | 9.45 (23-35)      | 9.45 (23-35)       | 25.59 (77-101)     | 25.59 (77-101)     |               |
|  |                          |                   | 11.81 (37-45)     | 11.81 (37-55)      |                    |                    |               |
| <b>GUIDE CARRYING BARS</b>                               | Length<br>(nr of plates) | in                | 4.92 (7-13)       | 4.92 (7-13)        | 13.78 (7-49)       | 13.78 (7-51)       | 19.68 (21-73) |
|  |                          |                   | 5.71 (15-21)      | 5.71 (15-21)       | 21.65 (51-75)      | 21.65 (53-75)      | 39.37 (>75)   |
|  |                          |                   | 9.84 (23-35)      | 9.84 (23-35)       | 25.59 (77-101)     | 25.59 (77-101)     |               |
|  |                          |                   | 11.81 (37-45)     | 11.81 (37-55)      |                    |                    |               |
| Standard Connections                                     | in                       | 1" F              | 1" F              | 2" M inox 304      | 2" M inox 304      | 3" F               |               |
| Connection Distance                                      | in                       | 14.57/2.56        | 14.57/2.56        | 23.78/5.71         | 23.78/5.71         | 33.46/6.61         |               |
| Distance between the plates                              | in                       | 0.12              | 0.12              | 0.13               | 0.13               | 0.14               |               |
| Approximate weights                                      | lb                       | 35.93+0.59 x n° P | 40.78+0.59 x n° P | 220.46+1.76 x n° P | 264.55+1.76 x n° P | 462.97+2.64 x n° P |               |
| Nominal pressure   | PSIG                     | 145               | 232               | 145                | 232                | 232                |               |
| Test pressure  | PSIG                     | 217.5             | 348               | 217.5              | 348                | 348                |               |
| Max. working temperature<br>(with standard EPDM gaskets) | °F                       | 284               | 284               | 284                | 284                | 230                |               |
| Max. working temperature<br>(with NBR gaskets)           | °F                       | 230               | 230               | 230                | 230                | 230                |               |

• Plate and Frame Connection: G Threads unless otherwise specified by customer requirements. See Data Submittal Sheets on our website. (NPT available upon request)

• **Brazed Plate Connection: MNPT**

Custom size and configuration available upon request.

Please call for sizing help and pricing **401.884.4943**

**SEE OUR WEBSITE FOR TANK SIZING CALCULATOR**

# ZILMET Brazed Plate Heat Exchanger

## HEATING SYSTEMS AND GENERAL APPLICATION

ZILMET heat exchangers, made of high quality 316 stainless steel and pure copper are particularly suitable to a wide variety of applications, including:

- Boiler components
- Hot water production with tank, hot water immediate production
- Traditional boiler heating
- Pool heating
- Thermal circuits decoupling
- District heating
- Solar system
- Full line available
- Ideal for hydronic and refrigeration use

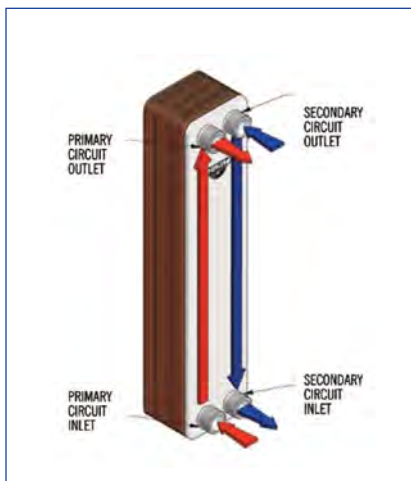

## REFRIGERATION/AIR CONDITIONING FIELD

ZILMET has recently extended its range of brazed plate heat exchangers introducing a range of products dedicated to the refrigeration and air conditioning area. The new series has been designed and built for evaporation and condensing units; they are also compatible with various types of refrigerants, including high-pressure ones such as 'R410A'.

Please contact us for more information on these refrigeration heat exchangers.

ZILMET heat exchangers are in full compliance with all safety and functionality requirements of Directive 97/23 / EC on pressure equipment.

**CUSTOM SIZES AND CONFIGURATIONS  
AVAILABLE UPON REQUEST.**

– Please call for sizing help and pricing [401.884.4943](tel:401.884.4943)

[SEE OUR WEBSITE FOR TANK SIZING CALCULATOR](#)

# ZILMET Brazed Plate Heat Exchangers

| Model Number      | Weight (Lbs) | Connection Size (NPT) | List Price (US \$) |
|-------------------|--------------|-----------------------|--------------------|
| ZB190 – 20 plates | 2.4          | 3/4"                  | \$352.10           |
| ZB207 – 14 plates | 1.8          | 3/4"                  | \$391.14           |
| ZB207 – 20 plates | 2.4          | 3/4"                  | \$462.10           |
| ZB207 – 30 plates | 3.5          | 3/4"                  | \$550.17           |
| ZB207 – 36 plates | 4.1          | 3/4"                  | \$582.26           |
| ZB207 – 40 plates | 4.6          | 3/4"                  | \$633.96           |
| ZB315 – 10 plates | 2.3          | 3/4"                  | \$625.86           |
| ZB315 – 16 plates | 3.2          | 3/4"                  | \$696.38           |
| ZB315 – 20 plates | 3.9          | 3/4"                  | \$758.79           |
| ZB315 – 24 plates | 4.6          | 3/4"                  | \$814.37           |
| ZB315 – 30 plates | 5.5          | 3/4"                  | \$906.71           |
| ZB315 – 40 plates | 7.2          | 3/4"                  | \$1,057.19         |

| Description            | Material                  |
|------------------------|---------------------------|
| shaped plates material | stainless steel AISI 316L |
| brazing material       | 99% copper                |
| connection material    | stainless steel AISI 316L |

| OPERATING CONDITIONS                    |              |
|---|--------------|
| max. working pressure primary circuit   | 72.5 PSIG    |
| max. working pressure secondary circuit | 145 PSIG     |
| max. operating temperature              | 14° F/248° F |

| Model Number       | Weight (Lbs) | Connection Size (NPT) | List Price (US \$) |
|--------------------|--------------|-----------------------|--------------------|
| ZB250 – 20 plates  | 8.4          | 1"                    | \$780.24           |
| ZB250 – 30 plates  | 11.0         | 1"                    | \$962.73           |
| ZB250 – 40 plates  | 13.7         | 1"                    | \$1,169.19         |
| ZB250 – 50 plates  | 16.3         | 1"                    | \$1,390.64         |
| ZB250 – 60 plates  | 19           | 1"                    | \$1,594.58         |
| ZB250 – 70 plates  | 21.6         | 1"                    | \$1,719.41         |
| ZB250 – 90 plates  | 26.9         | 1"                    | \$2,210.58         |
| ZB500 – 20 plates  | 14.6         | 1"                    | \$1,184.45         |
| ZB500 – 30 plates  | 19.6         | 1"                    | \$1,518.80         |
| ZB500 – 40 plates  | 24.5         | 1"                    | \$1,848.45         |
| ZB500 – 60 plates  | 34.4         | 1"                    | \$2,512.21         |
| ZB450 – 40 plates  | 48.6         | 2"                    | \$2,649.56         |
| ZB450 – 50 plates  | 58.4         | 2"                    | \$3,058.92         |
| ZB450 – 70 plates  | 78.2         | 2"                    | \$3,616.16         |
| ZB450 – 100 plates | 121.9        | 2"                    | \$5,880.78         |

| Description            | Material                  |
|------------------------|---------------------------|
| shaped plates material | stainless steel AISI 316L |
| brazing material       | 99% copper                |
| connection material    | stainless steel AISI 316L |

| Operating Conditions                    |               |
|---|---------------|
| max. working pressure primary circuit   | 435 PSIG      |
| max. working pressure secondary circuit | 435 PSIG      |
| max. operating temperature              | -58° F/392° F |

– Please call for sizing help and pricing **401.884.4943**

**SEE OUR WEBSITE FOR TANK SIZING CALCULATOR**



## STANDARD ON ALL ASME RATED EXPANSION TANKS



- 1** Pressure Gauge included and integrated
- 2** Bladder integrity monitor included
  - Allows for fast, accurate assessment of the tanks integrity. The indicator will change color from white to red in case of a compromised bladder or diaphragm
- 3** Easy Access Air Valve at work level on the side of the tank
- 4** Protective guard mount to prevent damage when shipping and installing
- 5** Higher factory pre-charge (at 40 PSIG) so it can be easily adjusted in the field as needed

### OTHER ASME ACCESSORIES AND UPGRADES INCLUDE

- Seismic Restraints
- Saddles to mount the tank horizontally
- Clips to secure a tank into place
- Available in 304 Stainless Steel
- Available in 316 Stainless Steel

– See page 24 for pricing.

ZILMET offers a full line of ASME rated expansion tanks for all applications. These tanks have recently been redesigned to include some new features and benefits that make servicing and installing much easier. The design and construction is manufactured to conform to ASME Section VIII, Div I.

– Please call for sizing help and pricing [401.884.4943](tel:401.884.4943)

[SEE OUR WEBSITE FOR TANK SIZING CALCULATOR](#)

# ZILMET Commercial Upgrades and Accessories

| Item                | Multiplier/Upcharge                                   |
|---------------------|---|
| 304/316 Stainless   | contact for pricing                                   |
| non ASME            | .85   |
| seismic restraints  | ranges based on tank diameter – see below for pricing |
| saddles             | see chart on right for pricing                        |
| replacement bladder | call for pricing and availability                     |

| Max. Working Pressure | Price Multiplier | Price Multiplier |
|-----------------------|------------------|------------------|
| 125                   | standard         | n/a              |
| 150                   | 1.25             | standard         |
| 200                   | 1.50             | 1.25             |
| 250                   | 1.75             | 1.50             |
| 300                   | 2.00             | 1.75             |

## SEISMIC RESTRAINTS (ONE PAIR PER TANK)

| Tank Diameter (In) | Weight per Pair (Lbs) | List Price per Pair |
|--------------------|-----------------------|---------------------|
| 16                 | 36.0                  | \$1,634.29          |
| 20                 | 36.0                  | \$1,647.62          |
| 24                 | 36.0                  | \$1,689.52          |
| 30                 | 70.0                  | \$1,942.86          |
| 36                 | 70.0                  | \$2,531.43          |
| 42                 | 120.0                 | \$4,026.67          |
| 48                 | 120.0                 | \$5,203.81          |
| 54                 | 305.0                 | \$6,120.00          |
| 60                 | 305.0                 | \$6,910.48          |
| 72                 | 305.0                 | \$7,702.86          |

## SADDLES

| Tank Diameter (In) | Weight per Pair (Lbs) | List Price per Pair |
|--------------------|-----------------------|---------------------|
| 10                 | 10.0                  | \$537.14            |
| 12                 | 12.0                  | \$573.33            |
| 14                 | 15.0                  | \$586.67            |
| 16                 | 21.0                  | \$611.43            |
| 20                 | 29.0                  | \$624.76            |
| 24                 | 35.0                  | \$687.62            |
| 30                 | 49.0                  | \$925.71            |
| 36                 | 57.0                  | \$1,030.48          |
| 42                 | 88.0                  | \$1,992.38          |
| 48                 | 115.0                 | \$2,360.00          |
| 54                 | 148.0                 | \$2,782.86          |
| 60                 | 171.0                 | \$4,127.62          |
| 66                 | 214.0                 | \$4,588.57          |
| 71                 | 257.0                 | \$5,049.52          |

## CLIPS

**TO SECURE TANK AT BASE  
(NOT SEISMIC APPROVED)**

| List Price |          |
|------------|----------|
| each       | \$268.00 |

3 clips per tank up to 800L. Above 800L use 4 clips.

# ZILMET Hydronic Expansion Tank with Replaceable Bladder (ZELA) ASME Rated Expansion Tank

ZELA-35 & ZELA-50

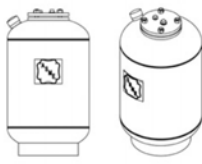

ZELA-85 thru ZELA-800L

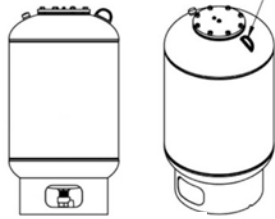

ZELA-1000 thru ZELA-15000

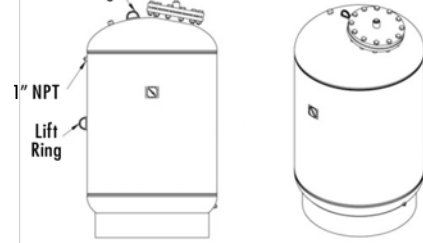

| Model Number | Volume (Gal) | Tank Weight (Lbs) | Connection Size (NPT) | Shipping Dimensions (LxWxH) | List Price (US \$) |
|--------------|--------------|-------------------|-----------------------|-----------------------------|--------------------|
| ZELA-35      | 10           | 40.0              | 3/4"                  | 12" x 12" x 23.5"           | \$2,795.84         |
| ZELA-50      | 13           | 50.0              | 3/4"                  | 14" x 14" x 24"             | \$3,079.48         |
| ZELA-85      | 23           | 90.0              | 1"                    | 16" x 16" x 37"             | \$3,700.78         |
| ZELA-130     | 35           | 125.0             | 1"                    | 20" x 20" x 37"             | \$4,754.29         |
| ZELA-200     | 53           | 210.0             | 1 1/2"                | 24" x 24" x 43"             | \$5,503.90         |
| ZELA-300     | 79           | 225.0             | 1 1/2"                | 24" x 24" x 55"             | \$6,030.65         |
| ZELA-400     | 106          | 300.0             | 1 1/2"                | 30" x 30" x 49"             | \$6,158.96         |
| ZELA-500     | 132          | 335.0             | 1 1/2"                | 30" x 30" x 57"             | \$6,489.87         |
| ZELA-600     | 158          | 360.0             | 1 1/2"                | 30" x 30" x 65"             | \$9,582.86         |
| ZELA-800L    | 211          | 475.0             | 1 1/2"                | 32" x 32" x 76"             | \$10,589.09        |

| Model Number | Volume (Gal) | Tank Weight (Lbs) | Connection Size (NPT) | Shipping Dimensions (LxWxH) | List Price (US \$) |
|--------------|--------------|-------------------|-----------------------|-----------------------------|--------------------|
| ZELA-1000    | 264          | 552.0             | 1 1/2"                | 36" x 36" x 75"             | \$12,979.74        |
| ZELA-1200    | 317          | 679.0             | 1 1/2"                | 36" x 36" x 87"             | \$13,574.03        |
| ZELA-1400    | 370          | 688.0             | 1 1/2"                | 36" x 36" x 99"             | \$14,776.10        |
| ZELA-1600    | 422          | 1046.0            | 1 1/2"                | 48" x 48" x 74"             | \$20,347.53        |
| ZELA-2000    | 528          | 1150.0            | 1 1/2"                | 48" x 48" x 87"             | \$22,319.48        |
| ZELA-2500    | 660          | 1444.0            | 2"                    | 48" x 48" x 95"             | \$29,186.86        |
| ZELA-3000L   | 792          | 1658.0            | 2"                    | 48" x 48" x 122"            | \$36,756.57        |
| ZELA-3000S   | 792          | 1868.0            | 2"                    | 60" x 60" x 80"             | \$51,182.86        |
| ZELA-4000    | 1056         | 2238.0            | 2"                    | 60" x 60" x 102"            | \$54,874.86        |
| ZELA-5000    | 1320         | 2617.0            | 2"                    | 60" x 60" x 125"            | \$57,274.29        |
| ZELA-7500    | 1980         | 3786.0            | 3"                    | 72" x 72" x 127"            | \$92,901.71        |
| ZELA-10000   | 2640         | 4628.0            | 3"                    | 72" x 72" x 159"            | \$108,590.86       |
| ZELA-15000   | 3963         | 5925.0            | 3"                    | 72" x 72" x 233"            | \$165,865.14       |

| Description | Material         |
|-------------|------------------|
| shell       | carbon steel     |
| connection  | carbon steel     |
| bladder     | heavy duty butyl |

| Operating Conditions       |           |
|----------------------------|-----------|
| precharge of               | 40 PSIG   |
| max. operating pressure    | 125 PSIG* |
| max. operating temperature | 240° F    |
| warranty                   | 1 year    |

## AVAILABLE UPON REQUEST

- Stainless Steel ASME tanks (304 & 316 Stainless)
- For Stainless steel tanks, add to suffix -SS-(304 or 316)
- Seismic restraints

\*150, 200 & 250 PSIG available

- The design and construction is manufactured to conform to ASME Section VIII, Div 1.

[SEE OUR WEBSITE FOR TANK SIZING CALCULATOR](#)

# ZILMET Hydronic Expansion Tank with Fixed Diaphragm (ZETA) ASME Rated Expansion Tank

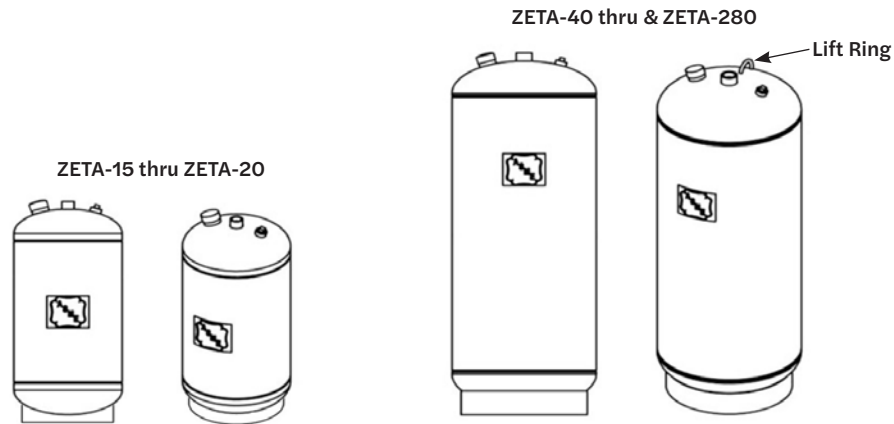

| Model Number | Volume (Gal) | Tank Weight (Lbs) | Connection Size (NPT) | Shipping Dimensions (LxWxH) | Acceptance Volume | List Price (US \$) |
|--------------|--------------|-------------------|-----------------------|-----------------------------|-------------------|--------------------|
| ZETA-15      | 7.8          | 42.0              | 3/4"                  | 12" x 12" x 19"             | 6.3               | \$1,229.09         |
| ZETA-20      | 10.9         | 52.0              | 3/4"                  | 12" x 12" x 25"             | 8.8               | \$1,262.86         |
| ZETA-40      | 25           | 84.0              | 1"                    | 16" x 16" x 34"             | 20.2              | \$1,951.69         |
| ZETA-60      | 35           | 97.0              | 1"                    | 16" x 16" x 45"             | 28.0              | \$2,255.58         |
| ZETA-80      | 45           | 148.0             | 1"                    | 20" x 20" x 39"             | 36.0              | \$2,903.90         |
| ZETA-100     | 60           | 175.0             | 1"                    | 20" x 20" x 50"             | 48.5              | \$3,045.71         |
| ZETA-120     | 70           | 259.0             | 1 1/2"                | 24" x 24" x 47"             | 56.5              | \$3,754.81         |
| ZETA-144     | 80           | 268.0             | 1 1/2"                | 24" x 24" x 50"             | 65.0              | \$4,024.94         |
| ZETA-180     | 90           | 283.0             | 1 1/2"                | 24" x 24" x 53"             | 73.0              | \$4,639.48         |
| ZETA-200     | 115          | 325.0             | 1 1/2"                | 24" x 24" x 67"             | 93.0              | \$4,754.29         |
| ZETA-240     | 140          | 362.0             | 1 1/2"                | 24" x 24" x 79"             | 113.5             | \$5,524.16         |
| ZETA-260     | 158          | 591.0             | 1 1/2"                | 30" x 30" x 64"             | 128.0             | \$7,621.49         |
| ZETA-280     | 211          | 752.0             | 1 1/2"                | 30" x 30" x 82"             | 171.0             | \$8,785.67         |

| Description | Material         |
|-------------|------------------|
| shell       | carbon steel     |
| connection  | carbon steel     |
| bladder     | heavy duty butyl |

| Operating Conditions       |          |
|----------------------------|----------|
| precharge of               | 40 PSIG  |
| max. operating pressure    |          |
| ZETA-15 thru ZETA-60       | 150 PSIG |
| ZETA-80 thru ZETA-280      | 125 PSIG |
| max. operating temperature | 240° F   |
| warranty                   | 1 year   |

## AVAILABLE UPON REQUEST

- Stainless Steel ASME tanks (304 & 316 Stainless)
- For Stainless steel tanks, add to suffix -SS-(304 or 316)
- Seismic restraints
- Ratings for 150, 200 & 250 PSIG

• The design and construction is manufactured to conform to ASME Section VIII, Div 1.

[SEE OUR WEBSITE FOR TANK SIZING CALCULATOR](#)

# ZILMET Thermal Expansion Tank with Replaceable Bladder (ZTXA) ASME Rated Expansion Tank

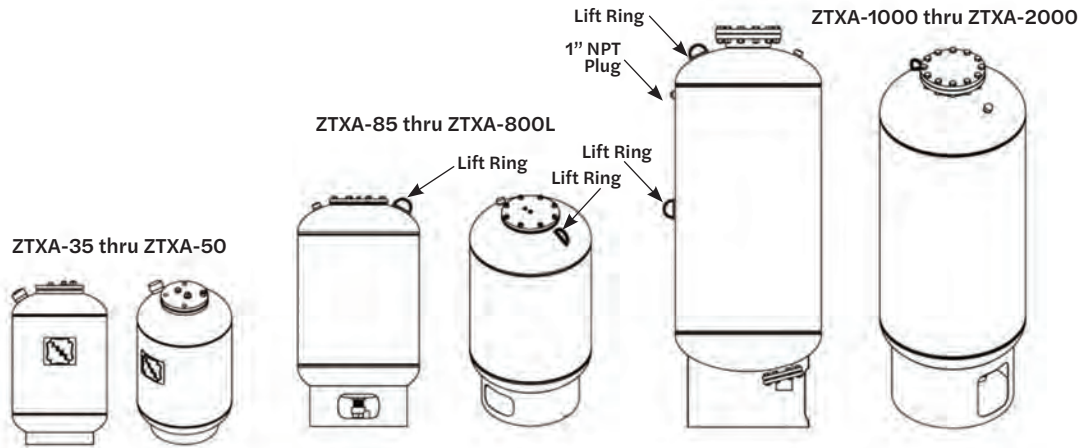

| Model Number | Volume (Gal) | Tank Weight (Lbs) | Connection Size (NPT) | Shipping Dimensions (LxWxH) | List Price (US \$) |
|--------------|--------------|-------------------|-----------------------|-----------------------------|--------------------|
| ZTXA-35      | 10           | 40.0              | 3/4"                  | 12" x 12" x 23.5"           | \$4,486.67         |
| ZTXA-50      | 13           | 50.0              | 3/4"                  | 14" x 14" x 24"             | \$4,786.67         |

| Model Number | Volume (Gal) | Tank Weight (Lbs) | Connection Size (NPT) | Shipping Dimensions (LxWxH) | List Price (US \$) |
|--------------|--------------|-------------------|-----------------------|-----------------------------|--------------------|
| ZTXA-85      | 23           | 90.0              | 1"                    | 16" x 16" x 37"             | \$4,906.67         |
| ZTXA-130     | 35           | 125.0             | 1"                    | 20" x 20" x 37"             | \$5,226.67         |
| ZTXA-200     | 53           | 210.0             | 1 1/2"                | 24" x 24" x 43"             | \$7,273.33         |
| ZTXA-300     | 79           | 225.0             | 1 1/2"                | 24" x 24" x 55"             | \$10,120.00        |
| ZTXA-400     | 106          | 300.0             | 1 1/2"                | 30" x 30" x 49"             | \$11,800.00        |
| ZTXA-500     | 132          | 335.0             | 2"                    | 30" x 30" x 57"             | \$12,333.33        |
| ZTXA-600     | 158          | 360.0             | 2"                    | 30" x 30" x 65"             | \$13,613.33        |
| ZTXA-800L    | 211          | 472.0             | 2"                    | 32" x 32" x 76"             | \$14,893.33        |

| Model Number | Volume (Gal) | Tank Weight (Lbs) | Connection Size (NPT) | Shipping Dimensions (LxWxH) | List Price (US \$) |
|--------------|--------------|-------------------|-----------------------|-----------------------------|--------------------|
| ZTXA-1000    | 264          | 735.0             | 3"                    | 36" x 36" x 86.5"           | \$17,273.33        |
| ZTXA-1200    | 317          | 745.0             | 3"                    | 36" x 36" x 98.5"           | \$18,333.33        |
| ZTXA-1400    | 370          | 900.0             | 3"                    | 36" x 36" x 110.5"          | \$19,460.00        |
| ZTXA-1600    | 422          | 1210.0            | 3"                    | 48" x 48" x 84"             | \$25,466.67        |
| ZTXA-2000    | 528          | 1305.0            | 3"                    | 48" x 48" x 96"             | \$27,186.67        |

| Description | Material                        |
|-------------|---------------------------------|
| shell       | carbon steel                    |
| connection  | stainless steel                 |
| bladder     | heavy duty butyl (FDA Approved) |

| Operating Conditions       |          |
|----------------------------|----------|
| precharge of               | 40 PSIG  |
| max. operating pressure    | 150 PSIG |
| max. operating temperature | 240° F   |
| warranty                   | 1 year   |

### AVAILABLE UPON REQUEST

- Stainless Steel ASME tanks (304 & 316 Stainless)
- For Stainless steel tanks, add to suffix -SS-(304 or 316)
- Seismic restraints
- Ratings for 200 & 250 PSIG

• The design and construction is manufactured to conform to ASME Section VIII, Div 1.

[SEE OUR WEBSITE FOR TANK SIZING CALCULATOR](#)

# ZILMET Thermal Expansion Tank with Replaceable Bladder – Full Flow (ZTXA-FF) ASME Rated Expansion Tank



ZTXA-1000-FF thru ZTXA-2000-FF

ZTXA-85-FF thru ZTXA-800L-FF

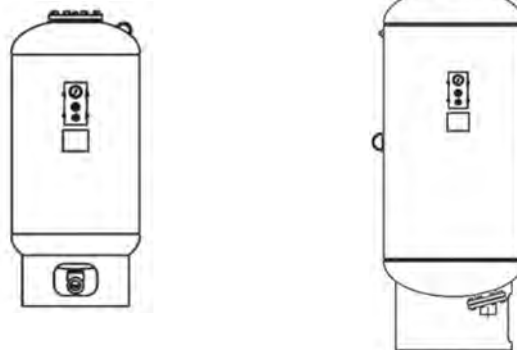

| Model Number | Pressure Rating (PSIG) | Volume (Gal) | Acceptance Volume (Gal) | Product Dimensions (LxWxH) | SYSTEM CONNECTION |      | Weight (Lbs) | List Price  |
|--------------|------------------------|--------------|-------------------------|----------------------------|-------------------|------|--------------|-------------|
|              |                        |              |                         |                            | Size (In)         | Type |              |             |
| ZTXA-85-FF   | 150                    | 23           | 23                      | 16" x 16" x 37"            | 1"                | NPT  | 90.0         | \$7,980.00  |
| ZTXA-130-FF  | 150                    | 35           | 35                      | 20" x 20" x 37"            | 1"                | NPT  | 132.0        | \$8,802.86  |
| ZTXA-200-FF  | 150                    | 53           | 53                      | 24" x 24" x 43"            | 1 1/2"            | NPT  | 220.0        | \$11,290.71 |
| ZTXA-300-FF  | 150                    | 79           | 79                      | 24" x 24" x 55"            | 1 1/2"            | NPT  | 236.0        | \$15,124.29 |
| ZTXA-400-FF  | 150                    | 106          | 106                     | 30" x 30" x 49"            | 1 1/2"            | NPT  | 315.0        | \$17,320.71 |
| ZTXA-500-FF  | 150                    | 132          | 132                     | 30" x 30" x 57"            | 2"                | NPT  | 347.0        | \$18,034.29 |
| ZTXA-600-FF  | 150                    | 158          | 158                     | 30" x 30" x 65"            | 2"                | NPT  | 378.0        | \$20,145.00 |
| ZTXA-800L-FF | 150                    | 211          | 211                     | 32" x 32" x 76"            | 2"                | NPT  | 503.0        | \$22,684.29 |

ZILMET type ZTXA-FF tanks are ASME removable bladder type pre-charged tanks designed as a multi-functional bladder for controlling system pressures in Thermal Expansion, Hydronic Expansion, and Hydro-Pneumatic applications. The ZTXA-FF design incorporates a unique flow-through design that promotes fluid mixing. Mixing of the fluid inside the bladder tank disrupts stagnant water, preventing growth of potentially harmful bacteria colonies. The water is contained in a heavy-duty butyl bladder, preventing tank corrosion and water-logging.

## REMOVABLE BLADDER TANK - ASME - 150 PSIG

| Model Number | Pressure Rating (PSIG) | Volume (Gal) | Acceptance Volume (Gal) | Product Dimensions (LxWxH) | SYSTEM CONNECTION |      | Weight (Lbs) | List Price  |
|--------------|------------------------|--------------|-------------------------|----------------------------|-------------------|------|--------------|-------------|
|              |                        |              |                         |                            | Size (In)         | Type |              |             |
| ZTXA-1000-FF | 150                    | 264          | 264                     | 36" x 36" x 74"            | 3"                | NPT  | 710.0        | \$26,318.57 |
| ZTXA-1200-FF | 150                    | 317          | 317                     | 36" x 36" x 86"            | 3"                | NPT  | 720.0        | \$27,087.86 |
| ZTXA-1400-FF | 150                    | 370          | 370                     | 36" x 36" x 99"            | 3"                | NPT  | 875.0        | \$29,466.43 |
| ZTXA-1600-FF | 150                    | 422          | 422                     | 48" x 48" x 72"            | 3"                | NPT  | 1,100.0      | \$37,913.57 |
| ZTXA-2000-FF | 150                    | 528          | 528                     | 48" x 48" x 85"            | 3"                | NPT  | 1,280.0      | \$40,384.29 |

**Notes:** Materials = Steel Shell, Heavy Duty Butyl Bladder; Maximum Pressure = 150 PSIG; Maximum Temperature = 240° F; Finish = Primer Painted Exterior; Factory Pre-charge = 40 PSIG; Also available in 200 & 250 PSIG rated models

[SEE OUR WEBSITE FOR TANK SIZING CALCULATOR](#)

# ZILMET Thermal Expansion Tank with Fixed Diaphragm (ZTTA) ASME Rated Expansion Tank

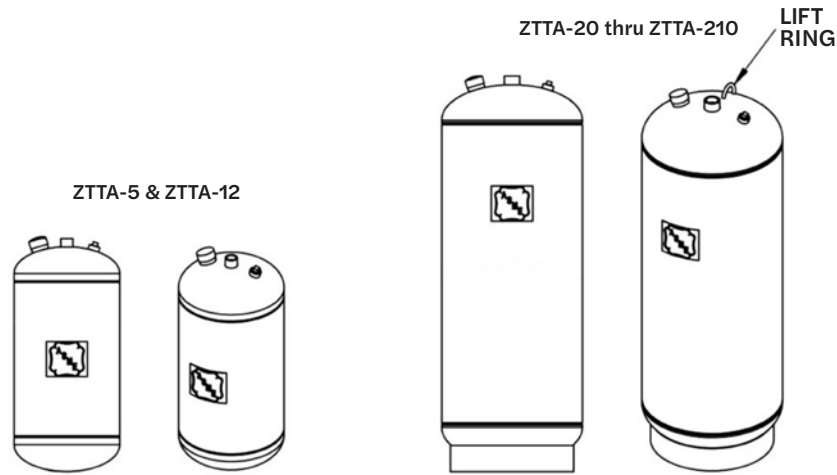

| Model Number | Volume (Gal) | Tank Weight (Lbs) | Connection Size (NPT) | Shipping Dimensions (LxWxH) | Acceptance Volume | List Price (US \$) |
|--------------|--------------|-------------------|-----------------------|-----------------------------|-------------------|--------------------|
| ZTTA-5       | 3.5          | 22.0              | 3/4"                  | 10" x 10" x 14"             | 2.3               | \$1,865.50         |
| ZTTA-12      | 5            | 28.0              | 3/4"                  | 12" x 12" x 14"             | 3.3               | \$2,200.00         |
| ZTTA-20      | 8            | 34.0              | 3/4"                  | 12" x 12" x 20"             | 5.3               | \$2,440.00         |
| ZTTA-30      | 15           | 50.0              | 1"                    | 16" x 16" x 23"             | 10.0              | \$2,753.33         |
| ZTTA-42      | 22           | 57.0              | 1"                    | 16" x 16" x 31"             | 14.5              | \$2,940.00         |
| ZTTA-60      | 26           | 62.0              | 1"                    | 16" x 16" x 34"             | 17.5              | \$3,626.67         |
| ZTTA-80      | 35           | 80.0              | 1"                    | 16" x 16" x 45"             | 23.5              | \$3,840.00         |
| ZTTA-100     | 45           | 110.0             | 1"                    | 20" x 20" x 39"             | 30.0              | \$4,066.67         |
| ZTTA-125     | 60           | 134.0             | 1"                    | 20" x 20" x 50"             | 40.0              | \$4,533.33         |
| ZTTA-160     | 70           | 177.0             | 1 1/2"                | 24" x 24" x 47"             | 47.0              | \$5,013.33         |
| ZTTA-180     | 80           | 184.0             | 1 1/2"                | 24" x 24" x 50"             | 53.0              | \$5,473.33         |
| ZTTA-210     | 90           | 193.0             | 1 1/2"                | 24" x 24" x 53"             | 60.0              | \$5,760.00         |

| Description | Material                        |
|-------------|---------------------------------|
| shell       | carbon steel                    |
| connection  | stainless steel                 |
| bladder     | heavy duty butyl (FDA Approved) |

| Operating Conditions       |          |
|----------------------------|----------|
| precharge of               | 40 PSIG  |
| max. operating pressure    | 150 PSIG |
| max. operating temperature | 240° F   |
| warranty                   | 1 year   |

## AVAILABLE UPON REQUEST

- Stainless Steel ASME tanks (304 & 316 Stainless)
- For Stainless steel tanks, add to suffix -SS-(304 or 316)
- Seismic restraints
- Ratings for 200 & 250 PSIG
- The design and construction is manufactured to conform to ASME Section VIII, Div 1.

[SEE OUR WEBSITE FOR TANK SIZING CALCULATOR](#)

# ZILMET Hydro-Pneumatic Tank with Replaceable Bladder (ZHXA) ASME Rated Expansion Tank



ZHXA-35 & ZHXA-50

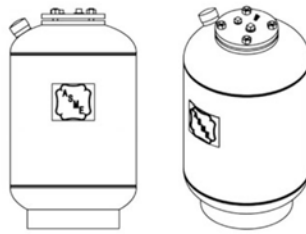

ZHXA-85 thru ZHXA-800L

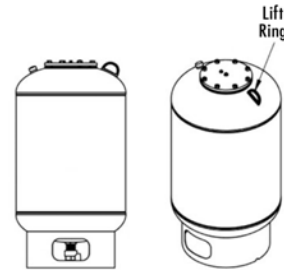

| Model Number | Volume (Gal) | Tank Weight (Lbs) | Connection Size (NPT) | Shipping Dimensions (LxWxH) | List Price (US \$) |
|--------------|--------------|-------------------|-----------------------|-----------------------------|--------------------|
| ZHXA-35      | 10           | 40.0              | 3/4" F                | 12" x 12" x 23.5"           | \$2,957.92         |
| ZHXA-50      | 13           | 50.0              | 3/4" F                | 14" x 14" x 24"             | \$3,160.52         |
| ZHXA-85      | 23           | 90.0              | 1" F                  | 16" x 16" x 37"             | \$4,126.23         |
| ZHXA-130     | 35           | 125.0             | 1" F                  | 20" x 20" x 37"             | \$5,118.96         |
| ZHXA-200     | 53           | 210.0             | 1 1/2" F              | 24" x 24" x 43"             | \$6,267.01         |
| ZHXA-300     | 79           | 225.0             | 1 1/2" F              | 24" x 24" x 55"             | \$7,516.36         |
| ZHXA-400     | 106          | 300.0             | 1 1/2" F              | 30" x 30" x 49"             | \$8,867.01         |
| ZHXA-500     | 132          | 330.0             | 2" F                  | 30" x 30" x 57"             | \$9,245.19         |
| ZHXA-600     | 158          | 360.0             | 2" F                  | 30" x 30" x 65"             | \$12,398.96        |
| ZHXA-700     | 185          | 400.0             | 1 1/2" M              | 30" x 30" x 80"             | \$13,945.06        |
| ZHXA-800L    | 211          | 475.0             | 2" F                  | 32" x 32" x 76"             | \$14,256.10        |

| Description | Material                        |
|-------------|---------------------------------|
| shell       | carbon steel                    |
| connection  | epoxy lined                     |
| bladder     | heavy duty butyl (FDA Approved) |

| Operating Conditions       |  |
|----------------------------|--|
| precharge of               | 40 PSIG  |
| max. operating pressure    | ZHXA-35 thru ZHXA-600, ZHXA800: 125 PSIG<br>ZHXA-700: 200 PSIG |
| max. operating temperature | 240° F   |

ZHXA-700

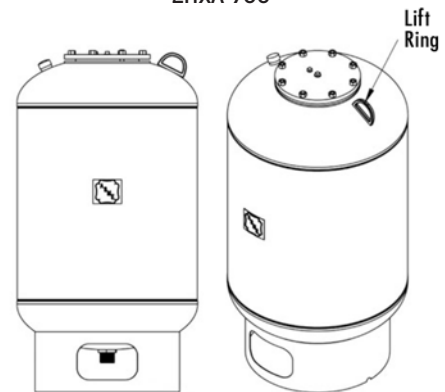

## AVAILABLE UPON REQUEST

- Stainless Steel ASME tanks (304 & 316 Stainless)
- For Stainless Steel tanks, add to suffix -SS-(304 or 316)
- Seismic restraints
- Ratings for 200 & 250 PSIG
- The design and construction is manufactured to conform to ASME Section VIII, Div 1.

[SEE OUR WEBSITE FOR TANK SIZING CALCULATOR](#)



# ZILMET Hydro-Pneumatic Tank with Replaceable Bladder (ZHXA) ASME Rated Expansion Tank

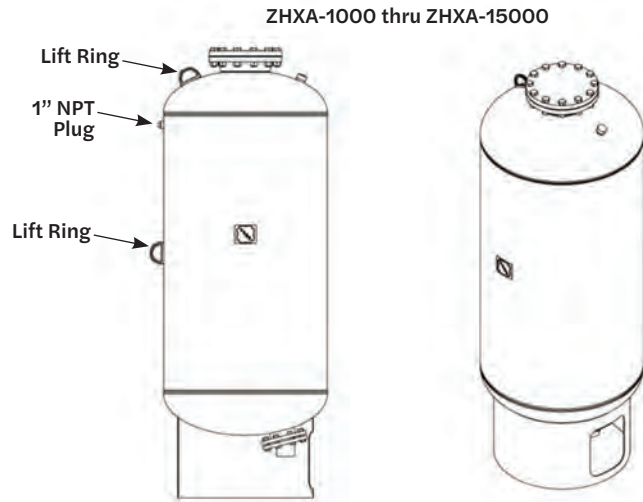

| Model Number | Volume (Gal) | Tank Weight (Lbs) | Connection Size (NPT) | Shipping Dimensions (LxWxH) | List Price (US \$) |
|--------------|--------------|-------------------|-----------------------|-----------------------------|--------------------|
| ZHXA-1000    | 264          | 655.0             | 3" F                  | 36" x 36" x 87"             | \$17,382.86        |
| ZHXA-1200    | 317          | 783.0             | 3" F                  | 36" x 36" x 98.5"           | \$18,503.90        |
| ZHXA-1400    | 370          | 793.0             | 3" F                  | 36" x 36" x 110.5"          | \$19,624.94        |
| ZHXA-1600    | 422          | 1,044.0           | 3" F                  | 48" x 48" x 84"             | \$24,953.25        |
| ZHXA-2000    | 528          | 1,154.0           | 3" F                  | 48" x 48" x 96"             | \$27,188.57        |
| ZHXA-2500    | 660          | 1,453.0           | 4" F                  | 48" x 48" x 110"            | \$33,712.21        |
| ZHXA-3000L   | 792          | 1,671.0           | 4" F                  | 48" x 48" x 138"            | \$36,845.71        |
| ZHXA-3000S   | 792          | 1,933.0           | 4" F                  | 60" x 60" x 93"             | \$48,015.58        |
| ZHXA-4000    | 1,056        | 2,305.0           | 4" F                  | 60" x 60" x 115"            | \$56,247.79        |
| ZHXA-5000    | 1,320        | 2,685.0           | 4" F                  | 60" x 60" x 138"            | \$73,644.16        |
| ZHXA-7500    | 1,980        | 3,906.0           | 4" F                  | 72" x 72" x 140"            | \$204,826.44       |
| ZHXA-10000   | 2,640        | 4,687.0           | 4" F                  | 72" x 72" x 172"            | \$325,402.20       |
| ZHXA-15000   | 3,963        | 6,249.0           | 4" F                  | 72" x 72" x 243"            | \$399,482.72       |

| Description | Material                        |
|-------------|---------------------------------|
| shell       | carbon steel                    |
| connection  | epoxy lined                     |
| bladder     | heavy duty butyl (FDA Approved) |

| Operating Conditions       |          |
|----------------------------|----------|
| precharge of               | 40 PSIG  |
| max. operating pressure    | 125 PSIG |
| max. operating temperature | 240° F   |
| warranty                   | 1 year   |

## AVAILABLE UPON REQUEST

- Stainless Steel ASME tanks (304 & 316 Stainless)
- For Stainless steel tanks, add to suffix -SS-(304 or 316)
- Seismic restraints
- Ratings for 150, 200 & 250 PSIG
- The design and construction is manufactured to conform to ASME Section VIII, Div 1.

[SEE OUR WEBSITE FOR TANK SIZING CALCULATOR](#)

# ZILMET Hydro-Pneumatic Tank with Fixed Diaphragm (ZHXT) ASME Rated Expansion Tank



ZHXT-400 thru ZHXT-480

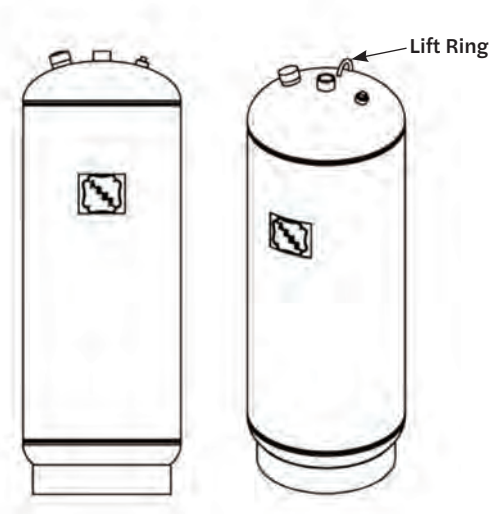

| Model Number | Volume (Gal) | Tank Weight (Lbs) | Connection Size (NPT) | Shipping Dimensions (LxWxH) | Acceptance Volume | List Price (US \$) |
|--------------|--------------|-------------------|-----------------------|-----------------------------|-------------------|--------------------|
| ZHXT-400     | 8            | 34.0              | 3/4"                  | 12" x 12" x 21"             | 6.3               | \$2,994.34         |
| ZHXT-401     | 15           | 64.0              | 1"                    | 16" x 16" x 26"             | 11.9              | \$3,180.78         |
| ZHXT-402     | 25           | 84.0              | 1"                    | 16" x 16" x 34"             | 19.8              | \$3,741.30         |
| ZHXT-403     | 35           | 97.0              | 1"                    | 16" x 16" x 46"             | 27.5              | \$3,802.08         |
| ZHXT-404     | 70           | 259.0             | 1 1/2"                | 24" x 24" x 47"             | 52.8              | \$5,692.99         |
| ZHXT-405     | 90           | 283.0             | 1 1/2"                | 24" x 24" x 53"             | 55.5              | \$5,936.10         |
| ZHXT-415     | 115          | 325.0             | 1 1/2"                | 24" x 24" x 67"             | 71.0              | \$11,846.29        |
| ZHXT-440     | 140          | 362.0             | 1 1/2"                | 24" x 24" x 79"             | 91.0              | \$13,679.12        |
| ZHXT-460     | 160          | 591.0             | 1 1/2"                | 30" x 30" x 62"             | 127.0             | \$16,398.20        |
| ZHXT-480     | 210          | 752.0             | 1 1/2"                | 30" x 30" x 80"             | 166.0             | \$19,645.08        |

| Description | Material                        |
|-------------|---------------------------------|
| shell       | carbon steel                    |
| connection  | epoxy lined                     |
| bladder     | heavy duty butyl (FDA Approved) |

| Operating Conditions       |          |
|----------------------------|----------|
| precharge of               | 40 PSIG  |
| max. operating pressure    | 200 PSIG |
| max. operating temperature | 240° F   |
| warranty                   | 1 years  |

## AVAILABLE UPON REQUEST

- Stainless Steel ASME tanks (304 & 316 Stainless)
- For Stainless steel tanks, add to suffix -SS-(304 or 316)
- Seismic restraints
- Ratings for 250 PSIG
- The design and construction is manufactured to conform to ASME Section VIII, Div 1.

[SEE OUR WEBSITE FOR TANK SIZING CALCULATOR](#)

# ZILMET Air and Dirt Separators (ZADS) ASME Rated

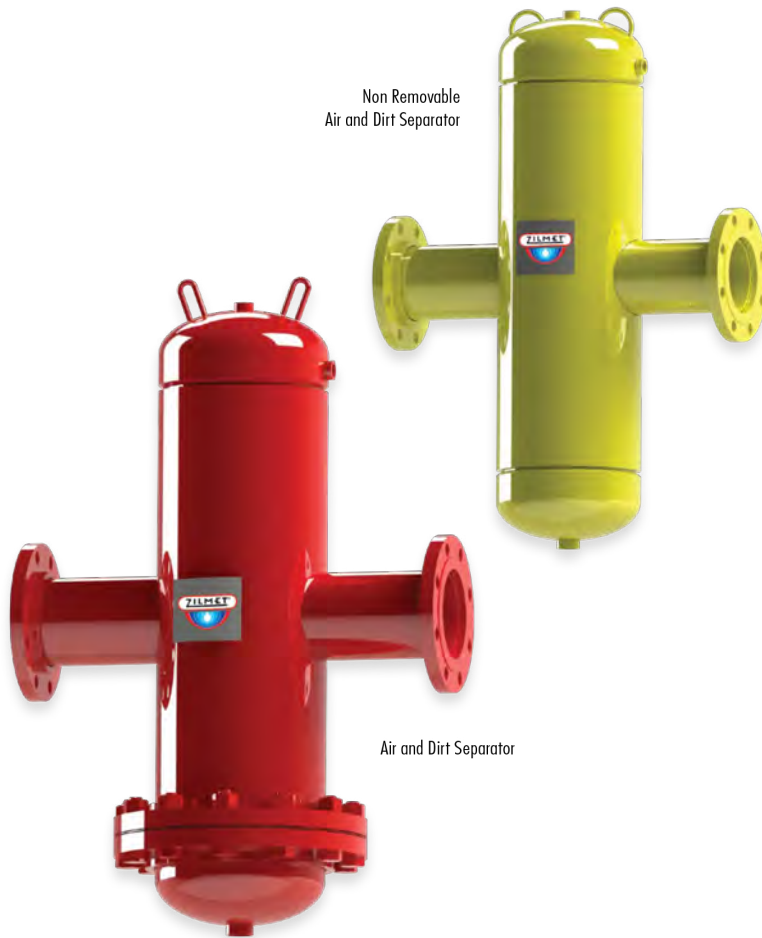

ZILMET Air and Dirt Separators (ZADS) are designed to eliminate entrained air and separate debris associated with start-up and continuous operation of any hydronic system. The design incorporates a removeable end cover for access to the coalescing media, a skim valve (optional) used to eliminate floating debris, and an air vent (optional) to automatically release air from the separator. The design and construction is manufactured to conform to ASME Section VIII , Div I.

| Standard                |                 |
|-------------------------|-----------------|
| material                | carbon steel    |
| coalescing media        | stainless steel |
| max. design temperature | 250° F          |
| max. design pressure    | 150 PSIG        |

| Options   |                 |
|---|-----------------|
| material  | stainless steel |
| coalescing media  | copper mesh     |
| optional magnetic filtration to remove ferrous particle |                 |

| ZADS Trim Package List Price \$265.00 |           |
|---------------------------------------|-----------|
| blow down valve – 1”                  | bronze    |
| skim valve – 1/2”                     | bronze    |
| air vent – 3/4”                       | cast iron |

## FOR HYDRONIC USE ONLY

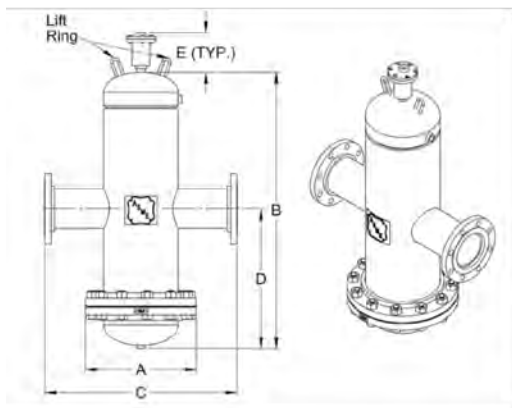

Air and Dirt Separator (ZADS)

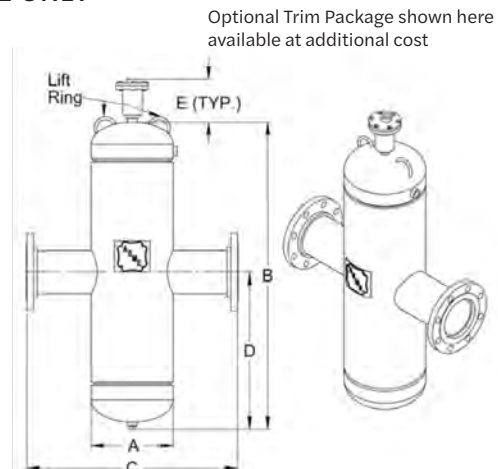

Non Removable Air and Dirt Separator (ZADSN)

Optional Trim Package shown here available at additional cost

[SEE OUR WEBSITE FOR TANK SIZING CALCULATOR](#)

# ZILMET Air and Dirt Separators (ZADS) ASME Rated

| AIR AND DIRT SEPARATOR (ZADS) Standard Velocity (ZADS) |                  |        |        |        |        |            |                    | REPLACEMENT CARTRIDGE | High Velocity (ZADS-HV) |        |            |                    | REPLACEMENT CARTRIDGE |
|--|------------------|--------|--------|--------|--------|------------|--------------------|-----------------------|-------------------------|--------|------------|--------------------|-----------------------|
| Model Number   | Flange Size (In) | A (In) | B (In) | C (In) | D (In) | Flow (GPM) | List Price (US \$) | List Price (US \$)    | C (In)                  | D (In) | Flow (GPM) | List Price (US \$) | List Price (US \$)    |
| ZADS-2   | 2                | 9      | 15.3   | 23     | 11.5   | 69         | \$4,493.88         | \$1,624.03            | 33                      | 16.5   | 105        | \$7,213.57         | \$2,441.60            |
| ZADS-2 NPT   | 2                | 9      | 9.0    | 23     | 11.5   | 69         | \$3,843.16         | \$1,624.03            | 33                      | 16.5   | 105        | \$6,557.29         | \$2,441.60            |
| ZADS-2.5   | 2.5              | 10     | 15.8   | 23     | 11.5   | 108        | \$4,927.70         | \$1,624.03            | 33                      | 16.5   | 155        | \$7,908.79         | \$2,441.60            |
| ZADS-2.5 NPT   | 2.5              | 10     | 10.5   | 23     | 11.5   | 108        | \$4,276.97         | \$1,624.03            | 33                      | 16.5   | 155        | \$7,263.63         | \$2,441.60            |
| ZADS-3   | 3                | 11     | 20.3   | 29     | 14.5   | 144        | \$6,006.67         | \$4,076.75            | 42                      | 21.0   | 225        | \$9,663.30         | \$6,090.10            |
| ZADS-3-NPT   | 3                | 11     | 12.8   | 29     | 14.5   | 144        | \$5,222.47         | \$4,076.75            | 42                      | 21.0   | 225        | \$8,887.65         | \$6,090.10            |
| ZADS-4   | 4                | 13.5   | 20.7   | 29     | 14.5   | 255        | \$7,380.42         | \$5,433.82            | 42                      | 21.0   | 405        | \$12,052.28        | \$8,236.93            |
| ZADS-5   | 5                | 16     | 27.8   | 39     | 19.5   | 398        | \$11,073.41        | \$8,159.07            | 59                      | 29.5   | 630        | \$16,946.61        | \$12,480.53           |
| ZADS-6   | 6                | 19     | 27.8   | 39     | 19.5   | 570        | \$15,845.38        | \$11,662.96           | 59                      | 29.5   | 910        | \$18,876.53        | \$13,909.90           |
| ZADS-8   | 8                | 23.5   | 33.7   | 49     | 24.5   | 945        | \$23,420.47        | \$17,246.94           | 75                      | 37.5   | 1,610      | \$38,036.71        | \$28,014.46           |
| ZADS-10  | 10               | 27.5   | 37.5   | 65     | 32.5   | 1,440      | \$36,351.50        | \$34,099.00           | 92                      | 46     | 2,450      | \$53,125.70        | \$49,577.31           |
| ZADS-12  | 12               | 32     | 42.5   | 76     | 38     | 2,100      | \$46,312.57        | \$34,099.00           | 110                     | 55     | 3,500      | \$67,335.93        | \$49,577.31           |

Non-ASME also available. For Hydronic Use Only.

## NON-REMOVABLE AIR AND DIRT SEPARATOR (ZADSN) Standard Velocity (ZADSN) High Velocity (ZADSN-HV)

| Model Number  | Flange Size (In) | A (In) | B (In) | C (In) | D (In) | Flow (GPM) | List Price (US \$) | C (In) | D (In) | Flow (GPM) | List Price (US \$) |
|---------------|------------------|--------|--------|--------|--------|------------|--------------------|--------|--------|------------|--------------------|
| ZADSN-2       | 2                | 4.5    | 15.3   | 23     | 11.5   | 69         | \$3,787.54         | 33     | 16.5   | 105        | \$6,523.92         |
| ZADSN-2-NPT   | 2                | 4.5    | 9.0    | 23     | 11.5   | 69         | \$3,136.82         | 33     | 16.5   | 105        | \$5,873.19         |
| ZADSN-2.5     | 2.5              | 5.5    | 15.8   | 23     | 11.5   | 108        | \$4,154.62         | 33     | 16.5   | 155        | \$7,124.58         |
| ZADSN-2.5-NPT | 2.5              | 5.5    | 10.5   | 23     | 11.5   | 108        | \$3,503.89         | 33     | 16.5   | 155        | \$6,479.42         |
| ZADSN-3       | 3                | 6.5    | 20.3   | 29     | 14.5   | 144        | \$5,139.04         | 42     | 21     | 225        | \$8,798.67         |
| ZADSN-3-NPT   | 3                | 6.5    | 12.8   | 29     | 14.5   | 144        | \$4,360.40         | 42     | 21     | 225        | \$8,020.02         |
| ZADSN-4       | 4                | 8.5    | 20.7   | 29     | 14.5   | 255        | \$6,507.23         | 42     | 21     | 405        | \$11,190.21        |
| ZADSN-5       | 5                | 10     | 27.8   | 39     | 19.5   | 398        | \$9,988.88         | 59     | 29.5   | 630        | \$15,867.63        |
| ZADSN-6       | 6                | 12     | 27.8   | 39     | 19.5   | 570        | \$14,543.94        | 59     | 29.5   | 910        | \$17,575.08        |
| ZADSN-8       | 8                | 16     | 33.7   | 49     | 24.5   | 945        | \$21,679.64        | 75     | 37.5   | 1610       | \$36,301.45        |
| ZADSN-10      | 10               | 20     | 37.5   | 65     | 32.5   | 1440       | \$34,399.33        | 92     | 46     | 2450       | \$51,173.53        |
| ZADSN-12      | 12               | 24     | 42.5   | 76     | 38     | 2100       | \$43,709.68        | 110    | 55     | 3500       | \$64,733.04        |

Non-ASME also available. For Hydronic Use Only.

[SEE OUR WEBSITE FOR TANK SIZING CALCULATOR](#)

# ZILMET Hot and Cold Water Buffer Tanks (ZCBT & ZHBT) ASME Rated

ZILMET ASME Chilled Water Buffer Tanks (ZCBT) are designed for use in chilled water systems with insufficient water volume capacity, in relation to the chiller capacity. The ZCBT Series Buffer Tanks effectively increase system volume and reduce the rate of change ( $\Delta T$ ) in the return water, resulting in improved temperature control, consistent system operation and controlled compressor cycling. The design and construction is manufactured to conform to ASME Section VIII, Div 1.



## STANDARD FEATURES FOR (ZCBT) & (ZHBT)

- ASME rated (125 PSIG at 450° F)
- Integral Ring Stand for Vertical Installation
- Top Air Vent Connection
- (ZCBT ) only: Internal Baffle

| Features (ZCBT ) and (ZHBT ) |   |
|------------------------------|---|
| material                     | carbon steel                            |
| max. pressure                | 125 PSIG                                |
| max. temperature             | 450° F                                  |
| finish                       | red oxide primer                        |
| auxilliary connections       | ¾" NPT top vent;<br>1" NPT bottom drain |

## (ZCBT) CHILLED WATER BUFFER TANKS

| Model Number | Gallons | Diameter (In) | Height (In) | Weight | 3"                 | 4"                 | 6"                 | 8"                 | 10"                |
|--------------|---------|---------------|-------------|--------|--------------------|--------------------|--------------------|--------------------|--------------------|
|              |         |               |             |        | List Price (US \$) | List Price (US \$) | List Price (US \$) | List Price (US \$) | List Price (US \$) |
| ZCBT-120     | 120.0   | 24            | 60          | 425    | \$8,898.78         | \$9,454.95         | \$10,011.12        | \$10,845.38        | \$11,957.73        |
| ZCBT-200     | 200.0   | 30            | 72          | 597    | \$9,454.95         | \$10,011.12        | \$10,567.30        | \$11,401.56        | \$12,513.90        |
| ZCBT-300     | 300.0   | 36            | 72          | 793    | \$12,513.90        | \$13,070.08        | \$13,626.25        | \$14,460.51        | \$15,572.86        |
| ZCBT-500     | 500.0   | 42            | 90          | 1391   | \$17,797.55        | \$18,353.73        | \$18,909.90        | \$19,744.16        | \$20,856.51        |
| ZCBT-850     | 850.0   | 54            | 96          | 2718   | \$26,696.33        | \$27,252.50        | \$27,808.68        | \$28,642.94        | \$29,755.28        |
| ZCBT-1040    | 1,040.0 | 60            | 96          | 3873   | \$31,145.61        | \$31,701.89        | \$32,258.06        | \$33,092.32        | \$34,204.67        |

## ZILMET HOT WATER BUFFER TANKS (ZHBT)

ZILMET ASME Hot Water Buffer Tanks (ZHBT) are designed for use with today's high efficiency systems that incorporate small modular low mass boilers. A properly sized ZILMET Hot Water Buffer Tank adds necessary thermal mass to the system to dampen fast transactions and minimize boiler cycling that occurs during zero or low domestic load conditions. The design and construction is manufactured to conform to ASME Section VIII , Div I.



## OPTIONAL FEATURES FOR (ZCBT) & (ZHBT)

- 1/2" Elastomeric Insulation
- Weather Resistant Coating
- Available with 1" to 2 1/2" NPT Connections
- 1"- 20" flange connections also available

## (ZHBT ) HOT WATER BUFFER TANKS

| Model Number | Gallons | Diameter (In) | Height (In) | Weight |
|--------------|---------|---------------|-------------|--------|
| ZHBT-120     | 120.0   | 30            | 60          | 248    |
| ZHBT-210     | 210.0   | 30            | 75          | 459    |
| ZHBT-300     | 300.0   | 30            | 72          | 781    |

\*Available in either 2 or 4 ports\*

Consult technical team for pricing and availability for higher working pressures and larger system connections.

Prices and lead times available upon request.

For Hydronic Use Only

[SEE OUR WEBSITE FOR TANK SIZING CALCULATOR](#)

# ZILMET Tangential Air Separators (ZPA) ASME Rated

Natural centrifugal forces allow heavier, air-free water to move towards the outer edges, while entrained air is captured by the stainless steel collection tube and released to the top of the separator. This air is then able to release from the system. Water exits near the bottom of the unit bubble-free which protects the system against noise, blockage, and damage commonly caused by entrained air.

## ZPA TANGENTIAL AIR SEPARATORS

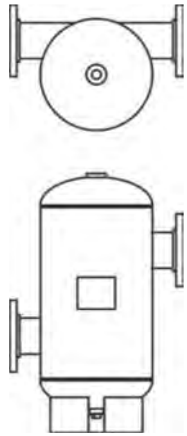

**Notes:** Materials = Steel;  
Maximum Pressure = 125 PSIG; Maximum Temperature = 450oF; Finish = Primer Painted Exterior; Stainless steel versions available upon request.

### LESS STRAINER

### SYSTEM CONNECTION

| Model Number | Pressure Rating (PSIG) | Product Dimensions (LxWxH) | Size (In) | Type    | Max GPM | Weight (Lbs) | List Price  |
|--------------|------------------------|----------------------------|-----------|---------|---------|--------------|-------------|
| ZPA-2        | 125                    | 12" x 16 5/8" x 22 1/2"    | 2"        | NPT     | 56      | 50.0         | \$1,148.81  |
| ZPA-2.5      | 125                    | 12" x 16 5/8" x 22 1/2"    | 2.5"      | NPT     | 90      | 55.0         | \$1,351.19  |
| ZPA-3        | 125                    | 12" x 19 3/4" x 25"        | 3"        | FLANGED | 190     | 60.0         | \$1,803.57  |
| ZPA-4        | 125                    | 14" x 21 3/4" x 32"        | 4"        | FLANGED | 300     | 900          | \$2,523.81  |
| ZPA-5        | 125                    | 14" x 21 3/4" x 32"        | 5"        | FLANGED | 530     | 1480         | \$3,029.76  |
| ZPA-6        | 125                    | 20" x 28" x 44"            | 6"        | FLANGED | 850     | 1910         | \$4,273.81  |
| ZPA-8        | 125                    | 20" x 28" x 44"            | 8"        | FLANGED | 1,900   | 379.0        | \$5,779.76  |
| ZPA-10       | 125                    | 30" x 41" x 60 1/2"        | 10"       | FLANGED | 3,200   | 5980         | \$9,267.86  |
| ZPA-12       | 125                    | 30" x 41" x 60 1/2"        | 12"       | FLANGED | 4,806   | 947.0        | \$14,190.48 |
| ZPA-14       | 125                    | 36" x 36 3/8" x 78"        | 14"       | FLANGED | 6,100   | 16800        | \$23,750.00 |
| ZPA-16       | 125                    | 48" x 60" x 108"           | 16"       | FLANGED | 8,000   | 2,300.0      | \$32,125.00 |
| ZPA-18       | 125                    | 54" x 66" x 124"           | 18"       | FLANGED | 9,700   | 3,235.0      | \$46,577.38 |
| ZPA-20       | 125                    | 60" x 72" x 138"           | 20"       | FLANGED | 12,000  | 5,100.0      | \$55,636.90 |
| ZPA-22       | 125                    | 66" x 78" x 150"           | 22"       | FLANGED | 15,000  | 6,150.0      | \$67,869.05 |
| ZPA-24       | 125                    | 66" x 80" x 150"           | 24"       | FLANGED | 17,000  | 7,210.0      | \$80,559.52 |

### WITH STRAINER

### SYSTEM CONNECTION

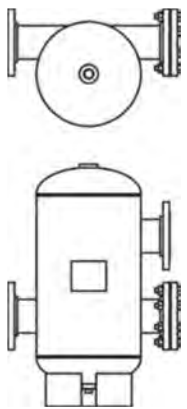

**Notes:** Materials = Steel;  
Maximum Pressure = 125 PSIG; Maximum Temperature = 450° F  
Finish = Primer Painted Exterior; Stainless Steel versions available upon request.

| Model Number | Pressure Rating (PSIG) | Product Dimensions (LxWxH) | Size (In) | Type    | Max GPM | Weight (Lbs) | List Price   |
|--------------|------------------------|----------------------------|-----------|---------|---------|--------------|--------------|
| ZPA-2S       | 125                    | 12" x 16 5/8" x 22 1/2"    | 2"        | NPT     | 56      | 55.0         | \$1,505.95   |
| ZPA-2.5S     | 125                    | 12" x 16 5/8" x 22 1/2"    | 2.5"      | NPT     | 90      | 61.0         | \$1,708.33   |
| ZPA-3S       | 125                    | 12" x 19 3/4" x 25"        | 3"        | FLANGED | 190     | 66.0         | \$2,428.57   |
| ZPA-4S       | 125                    | 14" x 21 3/4" x 32"        | 4"        | FLANGED | 300     | 99.0         | \$3,214.29   |
| ZPA-5S       | 125                    | 14" x 21 3/4" x 32"        | 5"        | FLANGED | 530     | 163.0        | \$4,476.19   |
| ZPA-6S       | 125                    | 20" x 28" x 44"            | 6"        | FLANGED | 850     | 210.0        | \$5,619.05   |
| ZPA-8S       | 125                    | 20" x 28" x 44"            | 8"        | FLANGED | 1,900   | 417.0        | \$7,648.81   |
| ZPA-10S      | 125                    | 30" x 41" x 60 1/2"        | 10"       | FLANGED | 3,200   | 658.0        | \$12,595.24  |
| ZPA-12S      | 125                    | 30" x 41" x 60 1/2"        | 12"       | FLANGED | 4,800   | 1042.0       | \$16,363.10  |
| ZPA-14S      | 125                    | 36" x 46 3/8" x 78"        | 14"       | FLANGED | 6,100   | 1848.0       | \$31,214.29  |
| ZPA-16S      | 125                    | 48" x 60" x 108"           | 16"       | FLANGED | 8,000   | 2,530.0      | \$46,166.67  |
| ZPA-18S      | 125                    | 54" x 66" x 124"           | 18"       | FLANGED | 9,700   | 3,559.0      | \$62,732.14  |
| ZPA-20S      | 125                    | 60" x 72" x 138"           | 20"       | FLANGED | 12,000  | 5,610.0      | \$75,494.05  |
| ZPA-22S      | 125                    | 66" x 78" x 150"           | 22"       | FLANGED | 15,000  | 6,765.0      | \$90,565.48  |
| ZPA-24S      | 125                    | 66" x 80" x 150"           | 24"       | FLANGED | 17,000  | 7,931.0      | \$111,101.19 |

[SEE OUR WEBSITE FOR TANK SIZING CALCULATOR](#)

# ZILMET Hydraulic Separators (ZPSA & ZPSAV) ASME Rated

ZILMET Primary/Secondary Header hydraulic separations are used in heating and cooling systems that require the primary and secondary loop of the system to be interlocked. The primary and secondary headers (ZPSA) are designed to keep both connected hydraulic circuits completely independent from one another and to provide a means for system air elimination. The ZILMET Primary/Secondary Header with Air/Dirt Separator (ZPSAV) builds on that functionality with the inclusion of internal coalescence coils in the tank that eliminate entrained air and separate debris associated with start-up and maintenance of the system. As a result, the ZPSA V replaces the need for an air/dirt separator. The design and construction is manufactured to conform to ASME Section VIII, Div I.



## STANDARD FEATURES

- Separates Primary and Secondary loop hydraulically
- Removes air from system
- Separates and collects sediment
- Easy installation
- **Optional magnet available at extra charge**

| Features         |                                   |
|------------------|-----------------------------------|
| material         | stainless steel                   |
| max. pressure    | 150 PSIG                          |
| max. temperature | 450° F                            |
| finish           | finish primer<br>painted exterior |

Legs come standard with 6" connection models and above. Consult technical team for pricing and availability for higher working pressures and larger system connections.

## ZPSA – PRIMARY/SECONDARY HEADER – WITH INTERNAL BAFFLE @ 150 PSIG

| Model Number | Connection | Diameter (In) | Height (In) | Width (In) | Flow (GPM) | Weight (Lbs) | List Price (US \$) |
|--------------|------------|---------------|-------------|------------|------------|--------------|--------------------|
| ZPSA-2       | 2"         | 6.6           | 34.3        | 14.8       | 65         | 90.0         | \$3,820.91         |
| ZPSA-2.5     | 2½"        | 6.6           | 39.3        | 14.8       | 68         | 115.0        | \$4,499.44         |
| ZPSA-3       | 3"         | 10.8          | 49.5        | 18.8       | 175        | 215.0        | \$7,141.27         |
| ZPSA-4       | 4"         | 10.8          | 70.3        | 22.8       | 180        | 225.0        | \$8,364.85         |
| ZPSA -5      | 5"         | 14.0          | 80.5        | 26.0       | 300        | 320.0        | \$11,295.88        |
| ZPSA-6       | 6"         | 18.0          | 93.8        | 30.0       | 500        | 330.0        | \$12,119.02        |
| ZPSA-8       | 8"         | 24.0          | 122.8       | 36.0       | 900        | 575.0        | \$15,678.53        |
| ZPSA-10      | 10"        | 30.0          | 149.3       | 42.0       | 1,420      | 935.0        | \$25,583.98        |
| ZPSA-12      | 12"        | 30.0          | 179.5       | 42.0       | 1,425      | 1,165.0      | \$34,883.20        |
| ZPSA-14      | 14"        | 42.0          | 199.3       | 54.0       | 1,650      | 2,430.0      | \$68,364.85        |
| ZPSA-16      | 16"        | 48.0          | 224.3       | 60.0       | 2,200      | 3,260.0      | \$89,043.38        |

## ZPSAV – PRIMARY/SECONDARY HEADER – WITH AIR AND DIRT SEPARATION @ 150 PSIG

| Model Number | Connection (In) | Diameter (In) | Height (In) | Width | Flow (GPM) | Weight (Lbs) | List Price (US \$) |
|--------------|-----------------|---------------|-------------|-------|------------|--------------|--------------------|
| ZPSAV-2      | 2"              | 6.6           | 34.3        | 14.8  | 65         | 120.0        | \$6,028.92         |
| ZPSAV-2.5    | 2½"             | 6.6           | 39.3        | 14.8  | 68         | 145.0        | \$6,785.32         |
| ZPSAV-3      | 3"              | 10.8          | 49.5        | 18.8  | 175        | 270.0        | \$9,421.58         |
| ZPSAV-4      | 4"              | 10.8          | 70.3        | 22.8  | 180        | 280.0        | \$11,006.67        |
| ZPSA V-5     | 5"              | 14            | 80.5        | 26.0  | 300        | 375.0        | \$14,838.71        |
| ZPSA V-6     | 6"              | 18            | 93.8        | 30.0  | 500        | 380.0        | \$16,685.21        |
| ZPSA V-8     | 8"              | 24            | 122.8       | 36.0  | 900        | 635.0        | \$23,337.04        |
| ZPSA V-10    | 10"             | 30            | 149.3       | 42.0  | 1,420      | 995.0        | \$37,958.84        |
| ZPSA V-12    | 12"             | 30            | 179.5       | 42.0  | 1,425      | 1,250.0      | \$46,957.73        |
| ZPSA V-14    | 14"             | 42            | 199.3       | 54.0  | 1,650      | 2,480.0      | \$92,030.03        |
| ZPSA V-16    | 16"             | 48            | 224.3       | 60.0  | 2,200      | 3,310.0      | \$119,860.96       |

For Hydronic Use Only

[SEE OUR WEBSITE FOR TANK SIZING CALCULATOR](#)

# ZILMET Shock and Surge Tanks (ZSSA) ASME Rated

Shock & Surge Tanks are specially designed hydro-pneumatic tanks used to absorb the harmful water hammer pressure wave in a piping system. When properly sized, these tanks are designed to capture the kinetic energy wave of a quick-closing valve (or other offending fixture) and limit the pressure spike that is otherwise created. Typically used in water well systems, municipal water distribution lines, pressure booster systems, and industrial water distribution systems.

## ZSSA SHOCK & SURGE TANKS

## REMOVABLE BLADDER TANK

## ASME

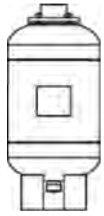

| Model Number | Pressure Rating (PSIG) | Volume (Gal) | Acceptance Volume (Gal) | Product Dimensions (LxWxH) | SYSTEM CONNECTION |      | Weight (Lbs) | List Price  |
|--------------|------------------------|--------------|-------------------------|----------------------------|-------------------|------|--------------|-------------|
|              |                        |              |                         |                            | Size (in)         | Type |              |             |
| ZSSA-35      | 250                    | 10           | 10                      | 12" x 12" x 26"            | 2 1/2"            | NPT  | 63           | \$14,408.57 |
| ZSSA-50      | 250                    | 13           | 13                      | 14" x 14" x 26"            | 2 1/2"            | NPT  | 74           | \$15,377.14 |

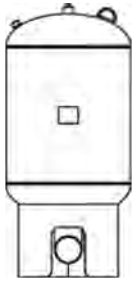

| Model Number | Pressure Rating (PSIG) | Volume (Gal) | Acceptance Volume (Gal) | Product Dimensions (LxWxH) | SYSTEM CONNECTION |         | Weight (Lbs) | List Price  |
|--------------|------------------------|--------------|-------------------------|----------------------------|-------------------|---------|--------------|-------------|
|              |                        |              |                         |                            | Size (in)         | Type    |              |             |
| ZSSA-85      | 250                    | 23           | 23                      | 16" x 16" x 30 1/2"        | 3"                | GROOVED | 116          | \$15,874.29 |
| ZSSA-130     | 250                    | 35           | 35                      | 20" x 20" x 30 1/2"        | 3"                | GROOVED | 135          | \$17,040.00 |
| ZSSA-200     | 250                    | 53           | 53                      | 24" x 24" x 46 1/2"        | 3"                | GROOVED | 250          | \$21,458.57 |
| ZSSA-300     | 250                    | 79           | 79                      | 24" x 24" x 58 1/2"        | 3"                | GROOVED | 360          | \$22,047.86 |
| ZSSA-400     | 250                    | 106          | 106                     | 30" x 30" x 52 1/2"        | 3"                | GROOVED | 430          | \$22,637.14 |
| ZSSA-500     | 250                    | 132          | 132                     | 30" x 30" x 63"            | 3"                | GROOVED | 525          | \$23,130.00 |
| ZSSA-600     | 250                    | 158          | 158                     | 30" x 30" x 71"            | 3"                | GROOVED | 640          | \$30,972.86 |
| ZSSA-700     | 250                    | 185          | 185                     | 30" x 30" x 81 1/2"        | 3"                | GROOVED | 749          | \$34,133.57 |
| ZSSA-800L    | 250                    | 211          | 211                     | 32" x 32" x 84"            | 3"                | GROOVED | 760          | \$40,555.71 |

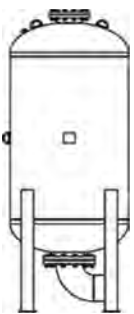

| Model Number | Pressure Rating (PSIG) | Volume (Gal) | Acceptance Volume (Gal) | Product Dimensions (LxWxH) | SYSTEM CONNECTION |         | Weight (Lbs) | List Price  |
|--------------|------------------------|--------------|-------------------------|----------------------------|-------------------|---------|--------------|-------------|
|              |                        |              |                         |                            | Size (in)         | Type    |              |             |
| ZSSA-1000    | 250                    | 264          | 264                     | 36" x 36" x 85"            | 10"               | FLANGED | 830          | \$47,922.86 |
| ZSSA-1200    | 250                    | 317          | 317                     | 36" x 36" x 107"           | 10"               | FLANGED | 1118         | \$58,236.43 |
| ZSSA-1400    | 250                    | 370          | 370                     | 36" x 36" x 119"           | 10"               | FLANGED | 1330         | \$62,070.00 |
| ZSSA-1600    | 250                    | 422          | 422                     | 48" x 48" x 92"            | 10"               | FLANGED | 1713         | \$73,223.57 |
| ZSSA-2000    | 250                    | 528          | 528                     | 48" x 48" x 105"           | 10"               | FLANGED | 2026         | \$84,027.86 |
| ZSSA-2500    | 250                    | 660          | 660                     | 48" x 48" x 122"           | 10"               | FLANGED | 2352         | \$91,763.57 |

**Notes:** Materials = Steel Shell, Heavy Duty Butyl Bladder; Maximum Pressure = 250 PSIG; Maximum Temperature = 240°F; Finish = Primer Painted Exterior; Factory Pre-charge = 40 PSIG

[SEE OUR WEBSITE FOR TANK SIZING CALCULATOR](#)



# ZILMET Glycol Make-Up (ZGMP) ASME Rated

Glycol make-up packages function by automatically supplying pressurized water, or water/glycol mixture to a closed loop space heating, chilled water, snowmelt, radiant heating, or process control system. The engineering package is designed to ensure that critical minimum system pressure levels are maintained. Benefits include preventing major floods in the event of a system rupture, eliminating the need for a backflow prevention system, protecting the system from freezing by utilizing a predetermined solution, ensuring EPA compliance, and maintaining pressure within the system. Included is a solution reservoir and a pump with control for precise metering.

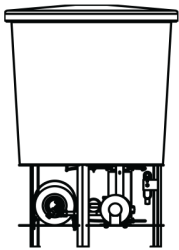

| ZGMP – SINGLE SYSTEM PACKAGE |           |                       |                            | SYSTEM CONNECTION |      | Weight (Lbs) | List Price  |
|------------------------------|-----------|-----------------------|----------------------------|-------------------|------|--------------|-------------|
| Model Number                 | Pump (HP) | Solution Volume (Gal) | Product Dimensions (LxWxH) | Size (In)         | Type |              |             |
| ZGMP-13050                   | 1/3       | 50                    | 34" x 34" x 45"            | 1/2"              | NPT  | 134          | \$12,578.57 |
| ZGMP-13100                   | 1/3       | 100                   | 34" x 34" x 68"            | 1/2"              | NPT  | 140          | \$13,056.43 |
| ZGMP-15050                   | 1/2       | 50                    | 34" x 34" x 45"            | 1/2"              | NPT  | 138          | \$13,662.86 |
| ZGMP-15100                   | 1/2       | 100                   | 34" x 34" x 68"            | 1/2"              | NPT  | 140          | \$14,145.00 |

**Notes:** Materials = Polyethylene solution tank, bronze pump, 110V, 60HZ Motor, steel base; Maximum Pressure = 70 PSIG discharge pressure; Maximum Temperature = 160° F; Finish = Gray Steel Base Exterior; Factory Discharge Pressure Setting = 12 PSIG

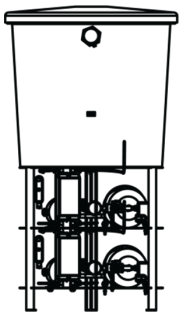

| ZGMPD – DUAL SYSTEMS/SINGLE PACKAGE |           |                       |                            | SYSTEM CONNECTION |      | Weight (Lbs) | List Price  |
|-------------------------------------|-----------|-----------------------|----------------------------|-------------------|------|--------------|-------------|
| Model Number                        | Pump (HP) | Solution Volume (Gal) | Product Dimensions (LxWxH) | Size (In)         | Type |              |             |
| ZGMPD-23050                         | 1/3"      | 50                    | 34" x 34" x 56"            | 1/2"              | NPT  | 214          | \$20,633.57 |
| ZGMPD-23100                         | 1/3"      | 100                   | 34" x 34" x 80"            | 1/2"              | NPT  | 255          | \$21,130.71 |
| ZGMPD-25100                         | 1/2"      | 50                    | 34" x 34" x 56"            | 1/2"              | NPT  | 218          | \$22,607.14 |
| ZGMPD-25100                         | 1/2"      | 100                   | 34" x 34" x 80"            | 1/2"              | NPT  | 259          | \$23,102.14 |

**Notes:** Materials = Polyethylene solution tank, bronze pump, 110V, 60HZ Motor, steel base; Maximum Pressure = 70 PSIG discharge pressure; Maximum Temperature = 160° F; Finish = Gray Steel Base Exterior; Factory Discharge Pressure Setting = 12 PSIG

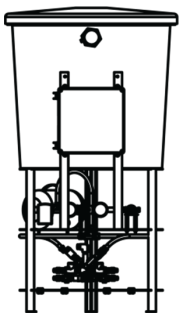

| ZGMPT – ALTERNATING TWIN PUMP PACKAGE |           |                       |                            | SYSTEM CONNECTION |      | Weight (Lbs) | List Price  |
|---------------------------------------|-----------|-----------------------|----------------------------|-------------------|------|--------------|-------------|
| Model Number                          | Pump (HP) | Solution Volume (Gal) | Product Dimensions (LxWxH) | Size (In)         | Type |              |             |
| ZGMPT-33050                           | 1/3"      | 50                    | 40" x 34" x 56"            | 1/2"              | NPT  | 236          | \$23,108.5  |
| ZGMPT-33050                           | 1/3"      | 100                   | 40" x 34" x 80"            | 1/2"              | NPT  | 226          | \$23,667.86 |
| ZGMPT-35050                           | 1/2"      | 50                    | 40" x 34" x 56"            | 1/2"              | NPT  | 240          | \$25,320.00 |
| ZGMPT-35100                           | 1/2"      | 100                   | 40" x 34" x 80"            | 1/2"              | NPT  | 230          | \$25,881.43 |

**Notes:** Materials = Polyethylene solution tank, bronze pump, 110V, 60HZ Motor, steel base; Maximum Pressure = 70 PSIG discharge pressure; Maximum Temperature = 160° F; Finish = Gray Steel Base Exterior; Factory Discharge Pressure Setting = 12 PSIG

# ZILMET Warranty and Pallet Count List

| Product                                     | Model                                  | Warranty Duration                       |
|---|--|---|
| Well Tanks                                  | Hydro Plus (ZHP)                       | 5 Year Limited Manufacturer's Warranty  |
| Thermal Expansion Tanks                     | Easy Pro (ZEP)                         | 5 Year Limited Manufacturer's Warranty  |
| Hydronic Expansion Tanks                    | Cal Pro (ZHT)                          | 5 Year Limited Manufacturer's Warranty  |
| Hydronic Flat Expansion Tanks               | ZILMET Flats (ZFT)                     | 5 Year Limited Manufacturer's Warranty  |
| Stainless Steel Tanks                       | Inox Pro (ZS) and Ultra Inox Pro (ZUP) | 5 Year Limited Manufacturer's Warranty  |
| Solar Expansion Tanks and Pre Solar Vessels | Solar Plus (ZSP) Pre Solar (VSG)       | 5 Year Limited Manufacturer's Warranty  |
| Magnetic Filters and Boiler Trim Kits       | All sizes                              | 5 Year Limited Manufacturer's Warranty  |
| Heat Exchangers                             | Brazed Plate and Frame                 | 1 Year Limited Manufacturer's Warranty  |
| Commercial Products                         | All models                             | 1 Year Limited Manufacturer's Warranty  |
| ActivFlo                                    | Nano, Solo, Whole House, Commercial    | 15 Year Limited Manufacturer's Warranty |
| ActivFlo Lite                               | ActivFlo Lite                          | 5 Year Limited Manufacturer's Warranty  |
| Maximizer                                   | All models                             | 5 Year Limited Manufacturer's Warranty  |

## SIDE CONNECTION WELL EXPANSION TANKS

### THERMAL EXPANSION TANKS

| Model Number | Layer Count | Pallet Count |
|--------------|-------------|--------------|
| ZEP1         | N/A         | 75/box       |
| ZEP5         | 18          | 180          |
| ZEP12        | 10          | 70           |
| ZEP18        | 8           | 48           |

| Model Number | Layer Count | Pallet Count |
|--------------|-------------|--------------|
| ZEP5         | 18          | 180          |
| ZEP12        | 10          | 70           |
| ZEP18        | 8           | 48           |
| ZHP24H       | 6           | 48           |
| ZHP104IL     | 6           | 24           |
| ZHP200F      | 6           | 18           |
| ZHP200BH     | 5           | 20           |
| ZHP200IL     | 6           | 18           |
| ZHP202       | 4           | 12           |
| ZHP202BH     | 3           | 12           |
| ZHP202SM     | 3           | 12           |
| ZHP202BV     | 4           | 12           |
| ZHP203       | 4           | 12           |
| ZHP204       | 4           | 8            |
| ZHP250       | 4           | 8            |
| ZHP251       | 4           | 8            |
| ZHP302       | N/A         | 6            |
| ZHP350       | N/A         | 4            |
| ZHP351       | N/A         | 3            |
| ZHP400       | N/A         | 2            |
| ZHP451       | N/A         | 2            |

### HYDRONIC EXPANSION TANKS

| Model Number | Layer Count | Pallet Count |
|--------------|-------------|--------------|
| ZHT8         | 20          | 120          |
| ZHT18        | 10          | 70           |
| ZHT24        | 8           | 48           |
| ZHT35        | 6           | 24           |
| ZHT35F       | 6           | 24           |
| ZHT50        | 6           | 18           |
| ZHT50F       | 6           | 18           |
| ZHT80        | 4           | 12           |
| ZHT105       | 4           | 10           |
| ZHT150       | 4           | 8            |
| ZHT200       | 4           | 8            |
| ZHT250       | 4           | 8            |
| ZHT300       | 4           | 6            |
| ZHT400       | N/A         | 4            |
| ZHT500       | N/A         | 2            |
| ZHT600       | N/A         | 2            |
| ZHT700       | N/A         | 2            |

### BOTTOM CONNECTION WELL TANKS

| Model Number | Layer Count | Pallet Count |
|--------------|-------------|--------------|
| ZHP202BC     | N/A         | 16           |
| ZHP202BVBC   | N/A         | 16           |
| ZHP203BC     | 4           | 10           |
| ZHP34BC      | 4           | 8            |
| ZHP204BC     | 4           | 8            |
| ZHP250BC     | 4           | 6            |
| ZHP302BC     | 4           | 6            |
| ZHP351BC     | 4           | 4            |

To view our latest shipping terms and conditions, please view:  
<https://www.zilmetusa.com/shipping-terms-and-conditions>

Please submit all orders to  
[orders@zilmetusa.com](mailto:orders@zilmetusa.com)  
 Please process all warranties at



SEE OUR WEBSITE FOR TANK SIZING CALCULATOR

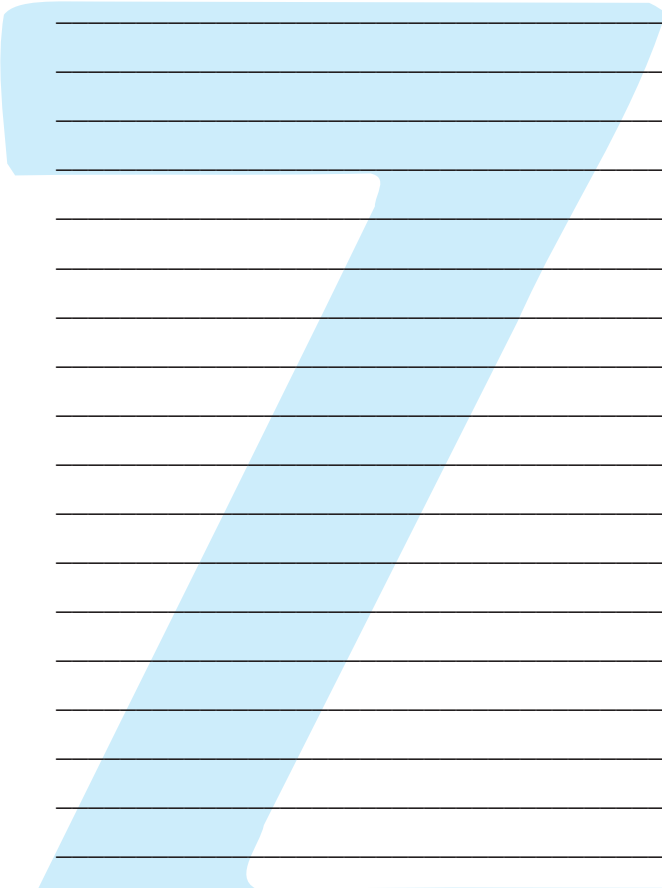

A series of horizontal lines for writing notes, starting from the top right and extending down to the bottom left of the page.



**ZILMET®**



globally renowned



Follow us on Instagram!



zilmetusa

To view our latest shipping terms  
and conditions, please view:

<https://www.zilmetusa.com/shipping-terms-and-conditions>

ZILMET USA Corp • 240 Commerce Park Road, North Kingstown, Rhode Island 02852  
P 401-884-4943 • F 401-287-4951

[INFO@ZILMETUSA.COM](mailto:INFO@ZILMETUSA.COM) | [ZILMETUSA.COM](http://ZILMETUSA.COM)

Rev. 1/24