



Submittal Form
ZETA Series
 Hydronic Expansion Tank with
 Fixed Diaphragm

9/25

Company Name: _____	Contact: _____
Bill to: _____	Date: _____
_____	Purchase Order No. _____
Ship to: _____	Notes _____
_____	_____

Description

Zilmet USA ZETA series are ASME fixed diaphragm type pre-charged expansion tanks. They are designed to absorb the expansion forces and control the pressure in heating/cooling systems. The system's expanded water (fully compatible with water/glycol mixtures) is contained in heavy-duty diaphragm that prevents tank corrosion and waterlogging problems. All ZETA expansion tanks can be installed vertically or horizontally.

Construction

Shell: Carbon Steel
 Membrane: Heavy Duty Butyl Fixed Diaphragm
 System Connection: Carbon Steel

Performance Limitations

Min/Max Design Temperatures: -20 to 240°F
 Maximum Design Pressure:
 ZETA 15 thru ZETA 60: 150 PSIG*
 ZETA 80 thru ZETA 280: 125 PSIG*
 *200 & 250 PSIG available

Model Number	Part Number	Tank Volume(Gal)	Acceptance Volume (Gal.)	Tagging Information	Quantity
ZETA-15	19010015	7.8	6.3		
ZETA-20	19010020	10.9	8.8		
ZETA-40	19010040	25	20.2		
ZETA-60	19010060	35	28		
ZETA-80	19010080	45	36		
ZETA-100	19010100	60	48.5		
ZETA-120	19010120	70	56.5		
ZETA-144	19010144	80	65		
ZETA-180	19010180	90	73		
ZETA-200	19010200	115	93		
ZETA-240	19010240	140	113.5		
ZETA-260	19010260	158	128		
ZETA-280	19010280	211	171		

Typical Specification

Furnish and install, as shown on plans, a _____ gallon _____" diameter X _____" (high) pre-charged steel expansion tank with a fixed heavy-duty butyl diaphragm. The tank shall be equipped with a NPT system connection, and a 0.302"-32 charging valve connection (standard tire valve) to facilitate the on-site charging of the tank to meet system requirements. The tank must be constructed in accordance with most recent addendum of Section VIII Division 1 of the ASME Boiler and Pressure Vessel Code.

Each tank shall be Zilmet USA model number ZETA-_____ or approved equal.

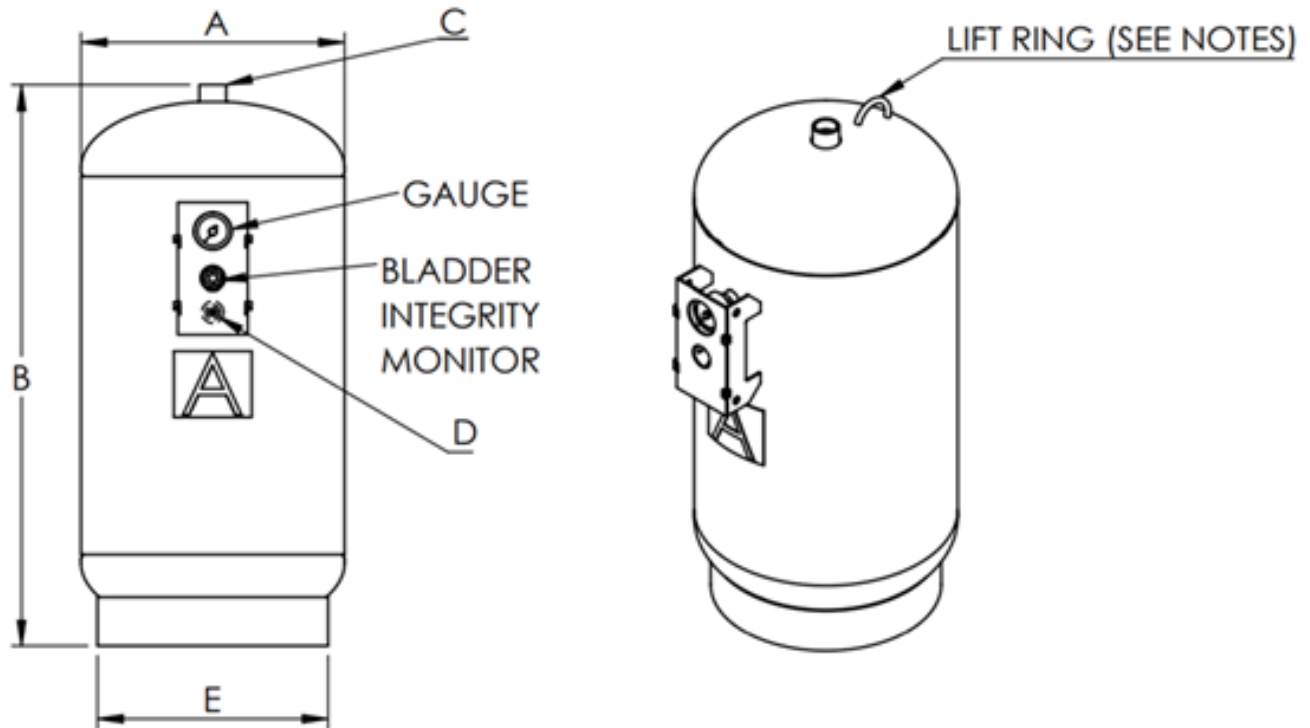

ZETA-15 thru ZETA-280

Model Number	Dimensions in Inches					Approx. Ship Weight (lbs)	
	A	B	System Connection	Charging Valve	E		
			C	D			
ZETA-15	12	19	3/4	0.302" -32NC	10	42	
ZETA-20		25				52	
ZETA-40	16	34	1		14	84	
ZETA-60		45				97	
ZETA-80	20	39	1 1/2		18	148	
ZETA-100		50				175	
ZETA-120	24	47			22	259	
ZETA-144		50					268
ZETA-180		53					283
ZETA-200		67					325
ZETA-240		79					362
ZETA-260	30	64			24	591	
ZETA-280		82		752			

Notes

- Tanks are factory precharged at 40psi and field adjustable.
- California code sight glass is standard.
- Pressure gauge and side mounted air stem are standard.
- For use up to 50% glycol.
- Available with seismic restraint mounting clips.
- 304 and 316 stainless steel ASME tanks available upon request.
- Lifting ring on ZETA40 thru ZETA280.